

Velvet Drive Marine Transmisson Service Manual

**71C - 72C Direct Drive
and Reduction Ratios
1.5:1, 1.88:1, 1.91:1, 2.1:1,
2.57:1, 2.91:1**

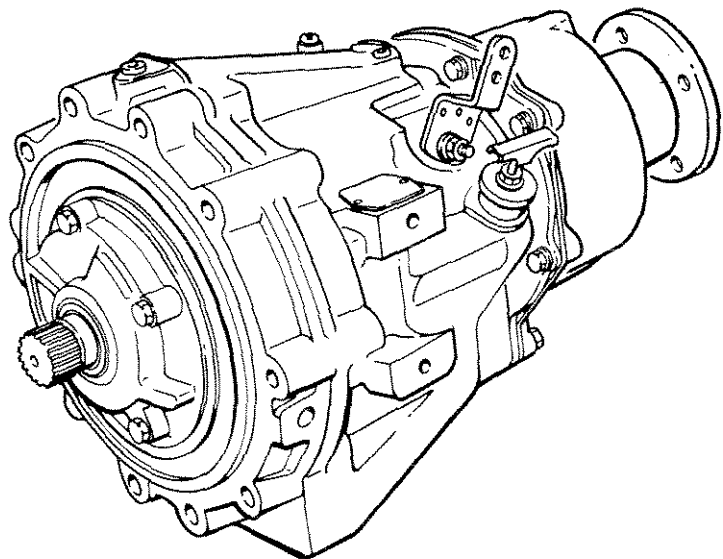
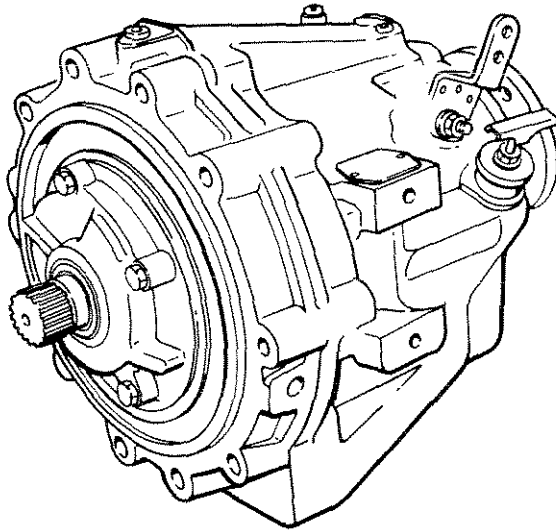

BorgWarner
Marine & Industrial Transmissions

Velvet Drive
BY BORG-WARNER

MARINE TRANSMISSIONS

BLANK

Rev-1 August 31, 1988

Price \$15.00

**71C - 72C Direct Drive
and Reduction Ratios
1.5:1, 1.88:1, 1.91:1, 2.1:1, 2.57:1, 2.91:1**

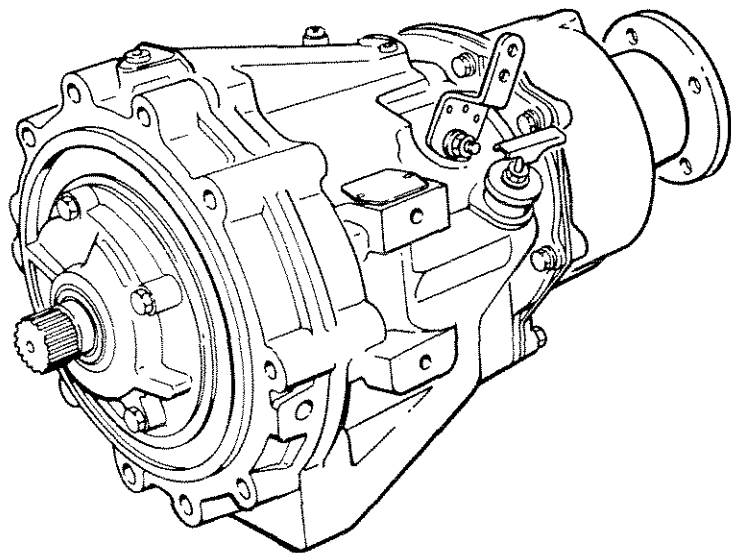
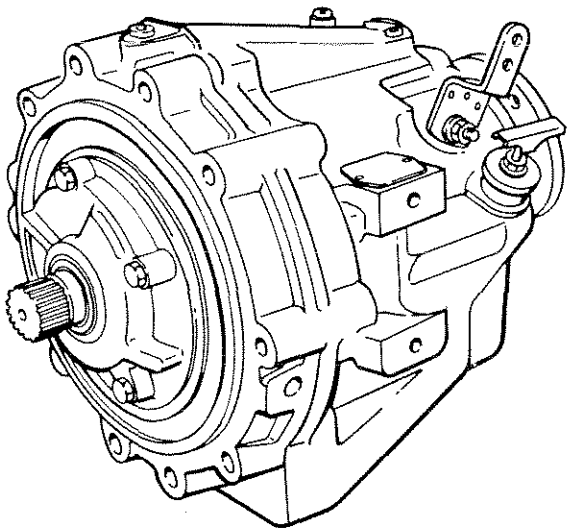

Borg-Warner
Automotive,
Inc.

Transmission
Systems

Post Office
Box 2688

Muncie
Indiana
47307

Telephone
317 286 6100
Telex
27 491

BLANK

This manual reflects the transmission models as of April 1986. Later models may have differences. The following direct-drive and reduction models are covered in this manual:

Transmission Assembly Number	Previous Trans. Assembly Number	Transmission Ratio	
		Forward	Reverse
10-17-000-001	AS1-71C	1:1	1:1
10-17-000-002	AS1-71CR	1:1	1:1
10-17-000-003	AS1-71CB	1:1	1:1
10-17-000-004	AS1-71CBR	1:1	1:1
10-17-000-005	AS2-71C	1.52:1	1.52:1
10-17-000-006	AS2-71CR	1.52:1	1.52:1
10-17-000-007	AS7-71C	1.91:1	1.91:1
10-17-000-008	AS7-71CR	1.91:1	1.91:1
10-17-000-009	AS3-71C	2.10:1	2.10:1
10-17-000-010	AS3-71CR	2.10:1	2.10:1
10-17-000-011	AS14-71C	2.57:1	2.57:1
10-17-000-012	AS14-71CR	2.57:1	2.57:1
10-17-000-013	AS15-71C	2.91:1	2.91:1
10-17-000-014	AS15-71CR	2.91:1	2.91:1
10-17-000-015	AS20-71C	1:1	1:1
10-17-000-016	AS20-71CR	1:1	1:1
10-17-000-108	None	1.88:1	1.88:1
10-18-000-001	AS11-72C	1:1	1.10:1
10-18-000-002	AS11-72CR	1:1	1.10:1
10-18-000-003	AS12-72C	1.52:1	1.68:1
10-18-000-004	AS12-72CR	1.52:1	1.68:1
10-18-000-106	None	1.88:1	2.07:1
10-18-000-005	AS17-72C	1.91:1	2.10:1
10-18-000-006	AS17-72CR	1.91:1	2.10:1
10-18-000-007	AS13-72C	2.10:1	2.31:1
10-18-000-008	AS13-72CR	2.10:1	2.31:1
10-18-000-009	AS14-72C	2.57:1	2.83:1
10-18-000-010	AS14-72CR	2.57:1	2.83:1
10-18-000-011	AS15-72C	2.91:1	3.20:1
10-18-000-012	AS15-72CR	2.91:1	3.20:1
10-18-000-013	AS20-72C	1:1	1.10:1
10-18-000-014	AS20-72CR	1:1	1.10:1
10-18-000-015	None	1:1	1.10:1
10-18-000-106	None	1:1	1.10:1
10-18-000-017	None	1:1	1.10:1

The following international symbols are used in this service manual.



WARNING: THIS SYMBOL WARNS OF POSSIBLE PERSONAL INJURY.



CAUTION: This symbol warns of possible damage to transmission.

OEM: Original Equipment Manufacturer (Boat/Engine Manufacturer).

TABLE OF CONTENTS

Section	Page
DESCRIPTION.....	1
A. Introduction.....	1
B. Theory of Operation.....	1
INSPECTION.....	4
A. General.....	4
B. Scheduled Inspection.....	4
MAINTENANCE.....	6
A. General.....	6
B. Lubrication.....	6
TROUBLESHOOTING.....	8
A. General.....	8
B. Guidelines.....	8
OVERHAUL.....	12
A. General.....	12
B. Disassembly.....	12
C. Cleaning.....	12
D. Inspection.....	12
E. Repair.....	12
F. Assembly.....	13
INSTALLATION.....	28
SPECIFICATIONS.....	37
1.523:1 REDUCTION UNITS.....	39
A. Description.....	39
B. Overhaul.....	39
1.88:1 AND 1.91:1 REDUCTION UNITS.....	48
A. Description.....	48
B. Overhaul.....	48
2.57:1 AND 2.91:1 REDUCTION UNITS.....	58
A. Description.....	58
B. Overhaul.....	58
2.10:1 REDUCTION UNITS.....	68
A. Description.....	68
B. Overhaul.....	68

LIST OF FIGURES

Title	Page
1. 71C and 72C Transmission Assembly	1
2. Typical Installation.	2
3. Forward Power Flow	2
4. Reverse Power Flow	2
5. Hydraulic Circuit Schematic	3
6. Bushing Installation	13
7A. Shift Cable Adjustment	28
7B. Oil to Cooler Outlet	28
8. 71C and 72C Transmission Assembly - Current Production	29
9. Optional Drive Gear Alarm Kits	35
10. 1.523:1 Reduction Units - Current Production	45
11. 1.523:1 Reduction Units - Early Production	47
12. 1.88:1 and 1.91:1 Reduction Units - Current Production	54
13. 1.88:1 and 1.91:1 Reduction Units - Early Production	57
14. 2.57:1 and 2.91:1 Reduction Units - Current Production	64
15. 2.57:1 and 2.91:1 Reduction Units - Early Production	67
16. 2.10:1 Reduction Units - Current Production	74
17. 2.10:1 Reduction Units - Early Production	77

LIST OF TABLES

Title	Page
1. Technical Specifications	1
2. Scheduled Inspections	4
3. Troubleshooting.	9
4. Bolt and Fastener Torques (Non-Lubricated)	37
5. Spring Dimensions	37
6. Test Pressures.	38

DESCRIPTION

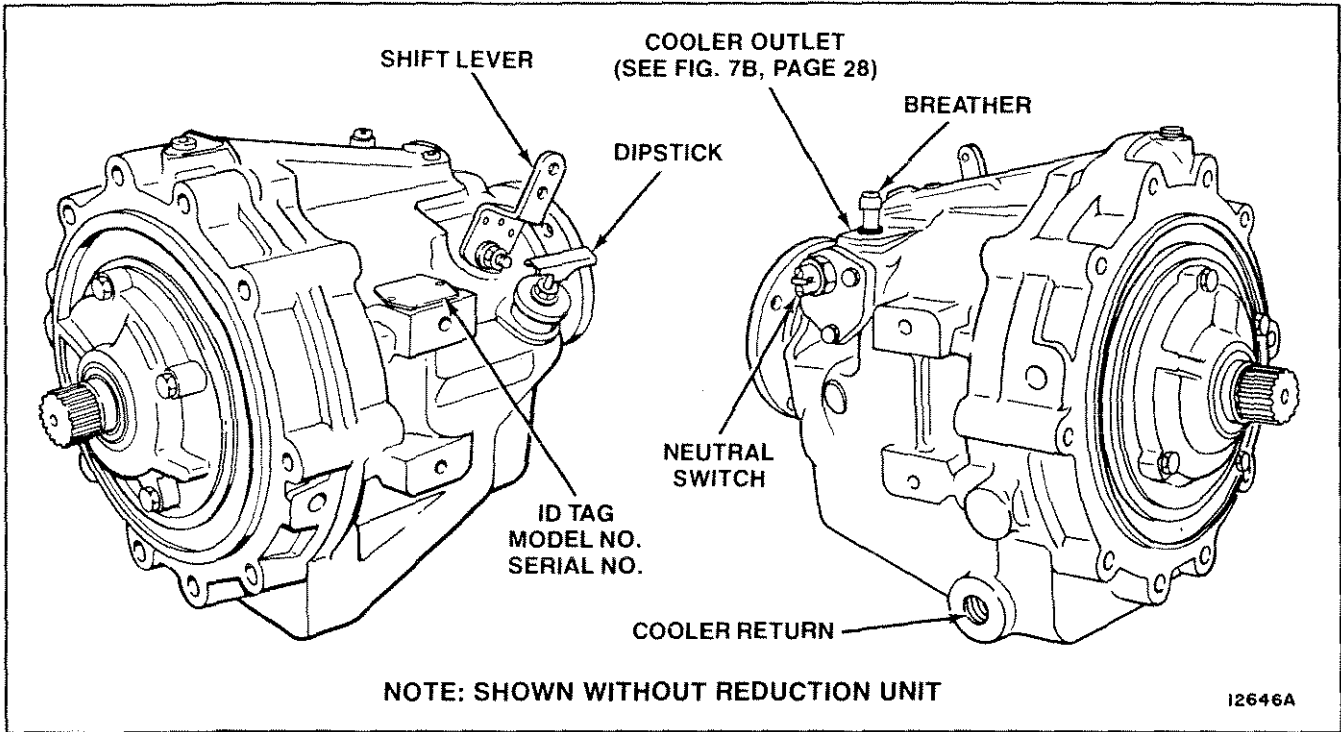

Figure 1. 71C and 72C Transmission Assembly

A. INTRODUCTION (See Figure 1).

The 71C and 72C transmissions consist of a planetary gear set and multiple disc clutches. The input and output shafts are in line.

Hydraulic Pressure is provided by a crescent type pump. The pump is driven at engine speed by the input shaft. Oil from the pump is sent to the control valve. The positions on the control

valve are forward-neutral-reverse. An internal regulator valve controls system pressure. Oil discharged by the regulator valve is sent to the oil cooler.

B. THEORY OF OPERATION.

General. Forward is direct drive. A planetary gear set (1.1 to 1.0 ratio for 72C, and 1.0 to 1.0 ratio for 71C) is used to obtain reverse.

Table 1. Technical Specifications

DESCRIPTION	MODEL 71C	MODEL 72C
Speeds	One Forward One Reverse	One Forward One Reverse
Horsepower		
Gasoline (maximum)	310 HP @ 4200 RPM	475 HP @ 4200 RPM
Diesel (maximum)	182 HP @ 3200 RPM	274 HP @ 3200 RPM
Torque and Input Speed	See Ratings Charts (Form No. 1237)	See Ratings Charts (Form No. 1237)
Approximate Dry Weight		
Direct Drive	95 lb.	109 lb.
Reduction	145 lb.	153 lb.

The transmission oil pump is driven by the input shaft. It supplies oil pressure to operate the clutch packs, lubricate parts, and provide cooling.

A damper plate is bolted to the engine flywheel. The damper plate is splined to connect to the input shaft. The damper plate reduces torsional vibrations to the transmission from the engine. (See Figure 2).

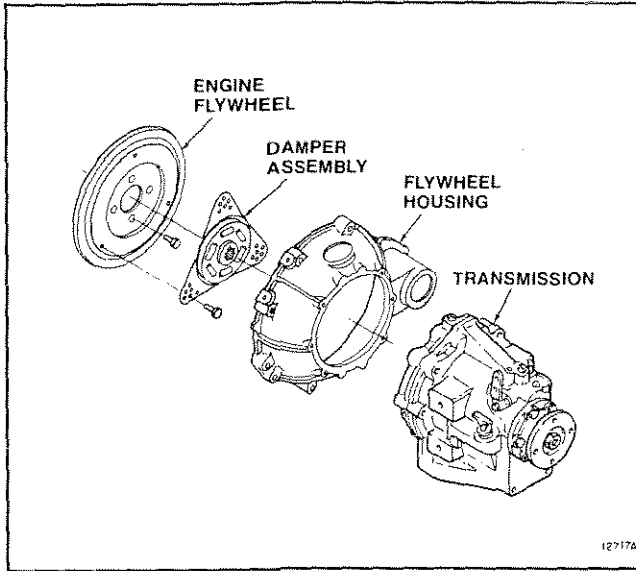

Figure 2. Typical Installation

Forward. The forward clutch is applied hydraulically when the shift lever is placed in the forward position. This connects the input shaft to the output shaft. The unit then transmits power at a 1 to 1 speed ratio in the same direction of rotation as the engine (See Figure 3).

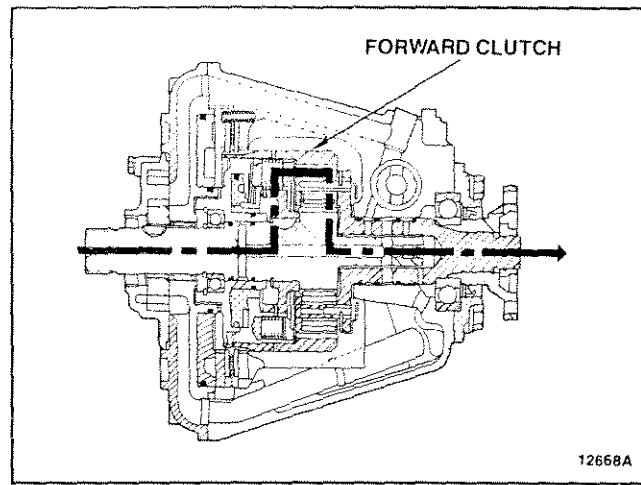

Figure 3. Forward Power Flow

Reverse. The reverse clutch is applied hydraulically when the shift lever is placed in the reverse position (See Figure 4). The applied clutch holds the ring gear. The input shaft and sun gear, driven by the engine, drive pinions, which drive the carrier output shaft. The output shaft turns opposite to engine rotation at a 1.1 to 1 speed reduction ratio for model 72C, and 1 to 1 speed ratio for model 71C.

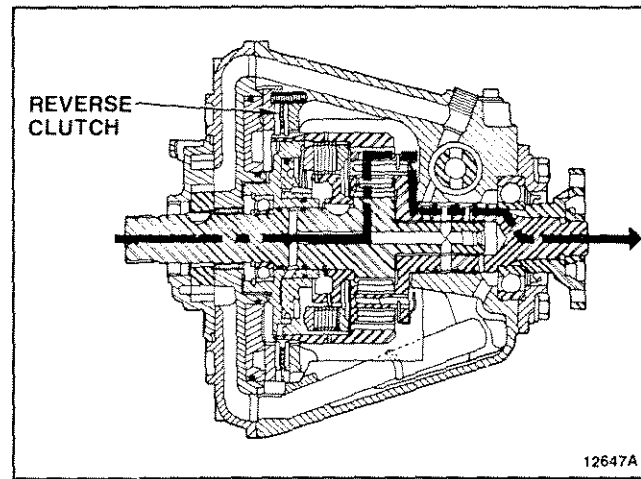

Figure 4. Reverse Power Flow

Hydraulic Circuit. Oil from the sump enters the pump suction passage and is directed to the pump (See Figure 5). The pump supplies oil under pressure through passages to the control and regulator valves.

Oil pressure on the end of the regulator valve moves the valve, compressing the spring. This movement allows oil to flow to the cooler.

Selector Valve. The selector valve shifts the transmission from neutral to forward or reverse. When selector valve is placed in the forward position, oil is directed to the forward clutch. When the selector valve is placed in reverse position, oil is fed to the reverse clutch. When one clutch is engaged the other is exhausted by a slot in the selector valve.

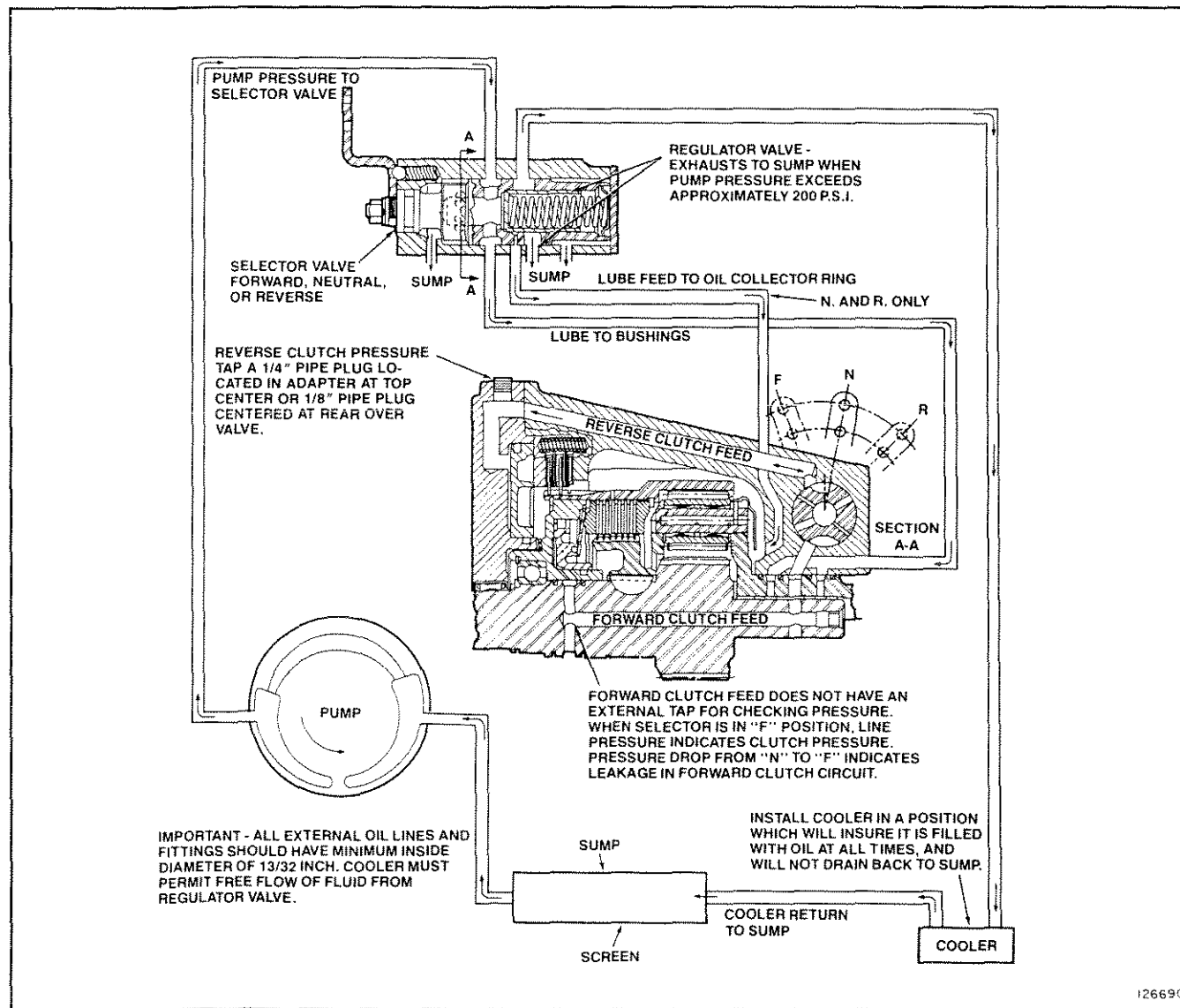

Figure 5. Hydraulic Circuit Schematic (Model 72C Direct-Drive Shown)

INSPECTION

A. GENERAL.

The transmission, cooler, cooler lines, and control linkage should be inspected at regular intervals. Regular inspections will ensure proper operation and help detect minor problems that can be corrected before they cause a transmission failure.

B. SCHEDULED INSPECTIONS (See Table 2).

The following recommended inspection intervals are based on normal operating conditions. Intervals should be adjusted for extremes of temperature or other adverse operating conditions.

Table 2. Scheduled Inspections



INSPECTION INTERVAL			
INSPECTION TASK	WEEKLY	PERIODIC 1 month or 100 hours, whichever comes first	SAFETY Annual or 1000 hours, whichever comes first
<p>GENERAL</p> <div style="display: flex; align-items: flex-start;"> <div style="margin-right: 10px;"></div> <div> <p>WARNING: FAILURE TO PERFORM THESE INSPECTIONS AT REQUIRED INTERVALS CAN RESULT IN INJURY TO PERSONNEL.</p> </div> </div> <p>Inspect control linkage and shift lever for operation. There should be no sticking, binding, or looseness.</p>		X	X
<p>OIL COOLER AND LINES</p> <div style="display: flex; align-items: flex-start;"> <div style="margin-right: 10px;"></div> <div> <p>CAUTION: Failure to perform these inspections at required intervals can result in transmission failure.</p> </div> </div> <p>Inspect cooler for signs of leakage, damage, or loose mounting bolts.</p> <p>Inspect all connection points for signs of leakage.</p>		X	X
		X	X

Table 2. Scheduled Inspections (Continued)

INSPECTION TASK	INSPECTION INTERVAL		
	WEEKLY	PERIODIC 1 month or 100 hours, whichever comes first	SAFETY Annual or 1000 hours, whichever comes first
<p>TRANSMISSION</p> <p>Inspect for damage or signs of leakage around housing and/or bolts.</p> <p> CAUTION: If oil is discolored or has been overheated (above 190°F) it must be replaced.</p> <p>Remove dipstick. Check oil for signs of water or other contaminants. Check (smell) oil for signs of burnt oil (overheating). If found, replace fluid. See Maintenance.</p> <p>Inspect breather. Check for movement of cap. If no movement replace breather.</p> <p>Check mounting bolts for tightness. If loose, tighten to torque specified in OEM manual.</p>	<p>X</p>	<p>X</p> <p>X</p>	<p>X</p>

MAINTENANCE

A. GENERAL.

Maintenance to the transmission will normally consist of the following items.

- Checking oil level or changing oil. Regular scheduled oil changes are an important part of transmission maintenance.



WARNING: SHIFT LINKAGE MUST BE ADJUSTED FOR PROPER OPERATION OF TRANSMISSION.

NOTE: For details on each of these adjustments refer to the OEM manual.

- Checking pressure in each circuit (if a problem is detected).



CAUTION: Transmission mounting bolts should be checked and tightened to torque specified in OEM manual. Do not overtighten! Damage to the transmission can result.

B. LUBRICATION.

Due to the various installation angles and oil cooler set-ups, it may be necessary to adjust your oil level.



WARNING: DO NOT REMOVE DIPSTICK WITH ENGINE RUNNING. HOT OIL CAN CAUSE BURNS.



CAUTION: Clean around the area of the dipstick, before removing. Small particles of dirt can cause damage to internal components and cause valves to stick.

Check Oil Level.

The transmission should be at operating temperature (190° max.) to get an accurate oil level reading. Oil will expand when it is heated. Oil will drain back from the cooler. Expansion and drain-back can significantly affect oil level.

Warm Oil Level Check.

When the transmission is at operating temperature, place selector lever in neutral. Shut off engine. Carefully remove transmission dipstick. Immediately insert clean dipstick and read oil level.

NOTE: Oil level must be checked immediately after engine shut-down to prevent an incorrect reading. Oil drains back into transmission from the cooler and cooler lines.

Add or remove oil if necessary. Repeat the above checking procedure as required until oil is at the dipstick mark.

Cold Oil Level Check.

For ease of checking the oil prior to engine start-up, a cold oil level mark can be made. To find the cold oil level mark, the oil level must first be set according to the warm oil level checking procedure. Then, let the boat sit overnight. Insert clean dipstick and read oil level.

Put a mark on the dipstick at the cold oil level reading.

You can use the new mark to check the oil level when cold. If oil level adjustment is needed, add oil to the new mark.

Type of Oil.

Dexron, Type F, or any hydraulic fluid which meets the C-3 oil specification is acceptable. Do not mix different brands. If engine doesn't exceed 3,000 R.P.M., a premium grade 30 weight engine oil is acceptable. SAE #40 and multi-viscosity oils are not recommended.

If the transmission oil temperature has exceeded 190° F or the alarm sounds, the oil must be changed in the transmission and cooler system.

Changing Oil.

Oil in transmission, cooler, and cooler lines should be changed after every 1,000 hours of operation or annually. Severe service conditions or high operating temperatures may require more frequent changes.

- Place selector lever in neutral. Run engine for five minutes at 1500 RPM. Shut down engine.



CAUTION: Clean around the area of drain plug, before removing. Small particles of dirt can cause damage to internal components and cause valves to stick.

- Drain oil from transmission, cooler, and cooler lines into a suitable container.

- Check oil for signs of metal or rubber particles.



CAUTION: A few small metal particles are normal. However, if large metal chips or a large number of particles are found, this could be an early sign of transmission failure. The transmission should be disassembled and inspected for internal damage.

NOTE: Particles of rubber can indicate cooler line wear. Each line should be inspected for cracks or fraying and should be replaced if damaged.

- Fill transmission with new oil.

NOTE: The amount of oil required will vary based on length of cooler lines. Use an amount equal to about three-fourths the quantity removed.

- Install dipstick. Run engine for two minutes to fill cooler and cooler lines with oil. Set oil level according to procedure at start of section B, Lubrication.

TROUBLESHOOTING

A. GENERAL.

Before troubleshooting the transmission, do the following.

- Check oil level and condition of oil. See Maintenance section for details.
- Check transmission, oil cooler and oil cooler lines for physical damage or leakage. Correct any problem.
- Check that engine, damper plate, or drive train alignment are not causing the problem.

Refer to OEM manual or Velvet-Drive Installation Manual (Form No. 1131) for drive train alignment requirements.

Perform all pressure checks at normal operating temperature. Refer to Specification section for details. Pressure gauges used should have a range of 0-200 or 0-300 psi. They must be accurate.

B. GUIDELINES.

When troubleshooting, shift into each selector position to determine when noise or problem occurs. Determine which parts are moving. This will help pinpoint the cause. Use the following information as a guide to common problems.

Damper Plate. Some transmission problems are damper plate related. Check and/or replace damper plate when the following problem occurs.

- Transmission “knocks” at idle or low RPM, then stops at 1,000 RPM or higher.

If the damper plate springs are too soft the sides of the windows will wear. If the springs are too hard the splines will wear. Consult engine OEM for correct damper plate recommended.

Clutches. Check and/or replace clutches if the following problem occurs.

- Excessive engine RPM (over the rated RPM). This can indicate a slipping clutch. The slipping clutch will usually squeal.



WARNING: DO NOT OPERATE TRANSMISSION IF THE FOLLOWING CONDITION IS SUSPECTED. FAILURE TO COMPLY CAN RESULT IN PERSONAL INJURY BECAUSE TRANSMISSION CAN NOT BE DIS-ENGAGED.

The slipping clutch will normally overheat. This can result in warped plates. In severe overheating plates can weld together. This will cause a tie up condition in transmission when the other clutch is applied.

Table 3. Troubleshooting

PROBLEM	CAUSE	CORRECTION
<p>LEAKS:</p> <p>1. At pump or output shaft seal.</p> <p>2. Between seal and bore.</p> <p>3. At gasket(s).</p> <p>4. Loss of oil with no trace of missing oil.</p> <p>5. Oil out of breather.</p>	<p>Faulty seal.</p> <p>Misalignment.</p> <p>Rough shaft.</p> <p>Rough housing bore.</p> <p>Loose bolts.</p> <p>Defective gaskets.</p> <p>Face(s) not flat.</p> <p>Oil leaking from cooler or cooler lines.</p> <p>Oil has been overheated. (Lost anti-foam additive)</p> <p>High or low oil level.</p> <p>Water in oil.</p>	<p>Replace.</p> <p>Correct.</p> <p>Replace.</p> <p>Replace seal.</p> <p>Torque bolts properly.</p> <p>Replace gaskets.</p> <p>Replace defective parts.</p> <p>Replace cooler, or cooler lines that are defective.</p> <p>Replace oil.</p> <p>Correct oil level.</p> <p>Change oil.</p>
<p>MALFUNCTION IN BOTH FORWARD AND REVERSE:</p> <p>1. Low oil pressure.</p> <p>2. No oil pressure.</p> <p>3. High oil temperature.</p>	<p>Regulator valve jammed.</p> <p>Internal leakage.</p> <p>Low oil level.</p> <p>Pump defective.</p> <p>Regulator valve jammed.</p> <p>Internal leakage.</p> <p>Pump defective.</p> <p>No oil.</p> <p>Pump incorrectly indexed.</p> <p>Regulator valve jammed.</p> <p>Cooler line defective.</p> <p>Oil cooler too small.</p> <p>Restrictions in cooler lines or cooler.</p>	<p>Clean and polish.</p> <p>Replace defective sealing rings.</p> <p>Add oil.</p> <p>Replace pump.</p> <p>Clean and polish.</p> <p>Replace defective parts.</p> <p>Replace pump.</p> <p>Add oil.</p> <p>Rotate pump to correct position.</p> <p>Clean and polish.</p> <p>Replace cooler line.</p> <p>Install larger cooler.</p> <p>Back flush to remove restrictions.</p>

Table 3. Troubleshooting (Continued)

PROBLEM	CAUSE	CORRECTION
MALFUNCTION IN BOTH FORWARD AND REVERSE: (Cont.)		
3. High oil temperature.	Defective cooler.	Replace cooler.
	Defective temperature sensor.	Replace sensor.
4. No power, noise.	Broken gear teeth — gears not meshed.	Replace defective parts.
5. No line pressure.	Heavy weight oil (90 weight).	Remove and use proper weight oil.
	Pump Incorrectly indexed.	Rotate pump to correct position.
	Oil inlet shield or screen blocked.	Inspect and clean.
6. Noisy in Forward and Reverse.	Misalignment of damper plate with engine, or misalignment of output shaft components.	Align drive train components.
	Damaged gears.	Replace damaged gears.
MALFUNCTION IN FORWARD OR REVERSE:		
1. Clutch drags or does not release.	Warped clutch plate.	Replace defective parts.
	Mechanical failure.	Replace defective parts.
	Tight pack clearance.	Increase clearance to specification.
2. Clutch does not apply.	Low pressure.	See low oil pressure.
	Defective parts.	Replace defective parts.
3. Harsh engagement.	High pressure - valve sticking.	Clean and polish regulator valve.
	Engine idle too fast.	Adjust engine idle.
	Linkage binding or misadjusted.	Repair as required and adjust to OEM spec.
4. Soft engagement.	Low pressure.	See low oil pressure.
5. Won't move or sluggish.	Forward clutch seized.	Replace defective parts.
	Worn or broken sealing rings.	Replace defective parts.

Table 3. Troubleshooting (Continued)

PROBLEM	CAUSE	CORRECTION
<p>MISCELLANEOUS PROBLEMS:</p> <p>1. Hydraulic noise or buzz.</p> <p>2. Gear noise in forward.</p> <p>3. Gear noise in reverse.</p>	<p>Low oil level, or air in hydraulic circuit.</p> <p>Regulator valve sticking.</p> <p>Broken, pitted, or cracked gear teeth.</p> <p>Broken, pitted, or cracked gear teeth.</p>	<p>Check oil level and fill if low. Operate engine in neutral at 1200 RPM to remove air.</p> <p>Clean and polish.</p> <p>Replace defective parts.</p> <p>Replace defective parts.</p>
<p>MALFUNCTION IN NEUTRAL:</p> <p>1. Drives in forward direction.</p> <p>2. Drives in reverse direction.</p> <p>3. Noisy in neutral only.</p> <p>4. Transmission overheating.</p>	<p>Broken sealing rings or bushings.</p> <p>Warped forward clutch plates or mechanical failure of clutch.</p> <p>Exhaust blocked in control valve.</p> <p>Warped reverse clutch plates or mechanical failure of clutch.</p> <p>Exhaust blocked in control valve.</p> <p>Low oil pressure. Pump gears worn.</p> <p>Oil level low.</p> <p>Oil level low. Cooler too small or restricted lines.</p> <p>Pump pressure low - worn or damaged pump.</p> <p>Clutches slipping.</p> <p>Internal leakage bypassing cooler.</p> <p>Temperature sensor defective.</p> <p>Incorrect type of oil.</p> <p>Regulator valve sticking.</p>	<p>Replace defective parts.</p> <p>Replace defective parts.</p> <p>Clean control valve.</p> <p>Replace defective parts.</p> <p>Clean control valve.</p> <p>Replace pump assembly.</p> <p>Add oil.</p> <p>Add oil. All external oil lines should have minimum inside diameter of 13/32". Cooler must permit free flow of oil.</p> <p>Check pressures. If low, inspect pump. If worn or damaged, replace.</p> <p>Check sealing rings. Replace if damaged.</p> <p>Locate and fix leak.</p> <p>Replace sensor.</p> <p>Drain, flush and replace with correct type of oil.</p> <p>Clean and polish.</p>

OVERHAUL

A. GENERAL.

Before removal and disassembly, review the following procedures. Use the proper hand tools, slings, or hoists for the job.



WARNING: KEEP WORK AREA, TOOLS, AND TRANSMISSION CLEAN. WIPE UP ANY SPILLED TRANSMISSION FLUID TO PREVENT ACCIDENTS. AS REQUIRED, WEAR SAFETY GLASSES, SAFETY SHOES AND A HARD HAT TO PREVENT PERSONAL INJURY.

B. DISASSEMBLY.

NOTE: Read OEM Vehicle manual for specific removal instructions.

Before starting disassembly, review the exploded-view shown in Figure 8. The transmission can be disassembled following the index numbers shown in Figure 8.

Seals. Remove O-rings, sealing rings, and oil seals carefully to prevent damage if they must be reused. It is best to replace these items.

Bearings. Do not remove bearings unless replacement is required, or cleaning can not be done properly.

- Keep matched parts or sets together. Do not reverse or mix them.

C. CLEANING.



WARNING: CLEANING SOLVENTS CAN BE TOXIC, FLAMMABLE, AN IRRITANT TO THE SKIN, OR GIVE OFF HARMFUL FUMES. AVOID PROLONGED CONTACT, INHALATION OF VAPORS, OR SMOKING. FAILURE TO COMPLY CAN RESULT IN INJURY OR DEATH TO PERSONS.

- Rinse all metal parts in solvent to remove dirt, grease, and transmission fluid.

- Take special care to remove solvent from all parts.

- Air-dry clutch plates.

- If O-rings are to be reused, air dry them.

D. INSPECTION.

Case. Inspect for cracks. Check sealing surfaces for nicks, scratches, or burrs that can cause leaks. Inspect output shaft bore for signs of wear on one side. This can indicate misalignment of prop shaft.

Gears. Inspect for unusual wear patterns, chipped, cracked, or broken teeth.

Bearings. Inspect for chips, cracks, galling, or missing bearings. Check for signs of overheating.

Threaded Parts. Inspect for stripped, damaged threads, or burrs.

Springs. Inspect for distortion, cracks, or other damage. Check springs against dimensions in Specification section.

E. REPAIR.

- Remove scratches, burrs, or minor surface defects with very fine emery cloth.

- Threaded holes can be retapped using the same size tap. Do not make the hole oversize.

- Repair or replace all damaged parts.

F. ASSEMBLY.



CAUTION: Threaded plugs, screws, bolts, and coupling nuts must be tightened to the torques shown in Table 4 to prevent premature failure of transmission.

- A new coupling nut must be used at assembly.
- Prior to assembly, dip or coat internal parts with transmission fluid. Let excess fluid drain off.
- Use a light coat of vasoline to position or hold a gasket, O-ring, or small part for assembly. Apply to sealing rings before assembly.
- Inspect assemblies pressed together for proper fit and position.

- Check that each snap ring is fully engaged in groove.
- Threaded plugs, screws, and bolts should be tightened to the torques shown in Table 4.

NOTE: The following procedures are correct for most transmissions. Minor differences may be found on some models.

- Assemble the transmission using the following procedures. If a reduction unit is mounted to the transmission, refer to the correct section at the back of this manual for assembly procedures.



CAUTION: Transmissions manufactured prior to September 1978 used bushings instead of sealing rings. If bushings were in case they must be installed before assembly of transmission. See Figure 6 for details.

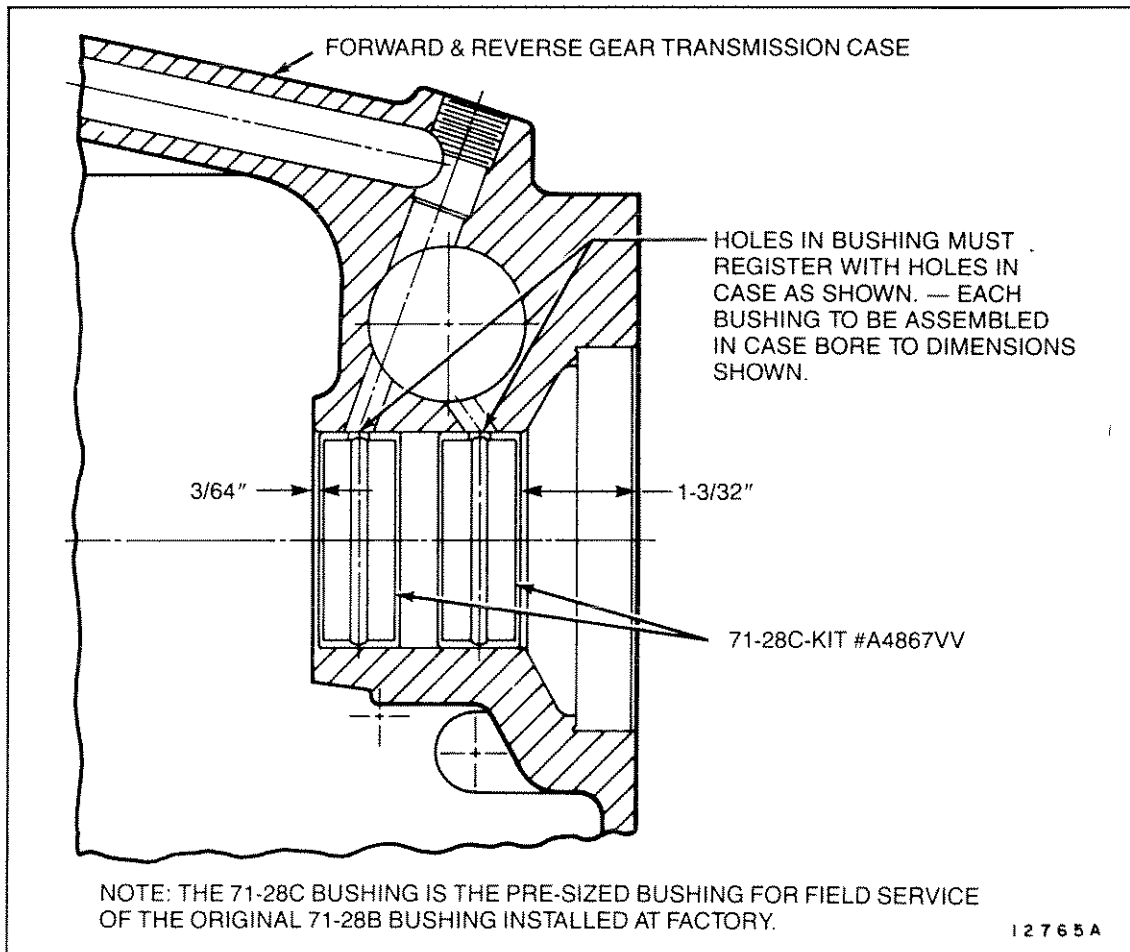

Figure 6. Bushing Installation

STEP 1. If removed, install the following parts in case (98). Tighten threaded parts to torque shown in Table 4.

Press bearing (7) into back of case (98).

Apply loctite #92, or equivalent, to threads of pipe plugs (96 and 97) and thread into top of case (98).

Apply loctite #592, or equivalent, to threads of dipstick tube (18) and thread into side of case (98).

NOTE: Plug (88) is a plastic shipping plug and should be installed hand-tight.

STEP 2. Install shield (92) in case (98) with slot facing bottom of case (98). Install washer (91) and spring (90) inside shield (92).

Apply loctite #92, or equivalent, to threads of bushing (89). Thread bushing (89) into side of case (98) and tighten to torque shown in Table 4.

NOTE: Plug (88) is a plastic shipping plug and should be installed hand-tight.

STEP 3. Install baffle (87) in case (98). Place thrustwasher (86) on face of bearing bore. Notch in thrustwasher (86) must align with notch in case (98).



CAUTION: Thrustwasher is used only on some models. (See Model Chart 71C and 72C Transmissions.)

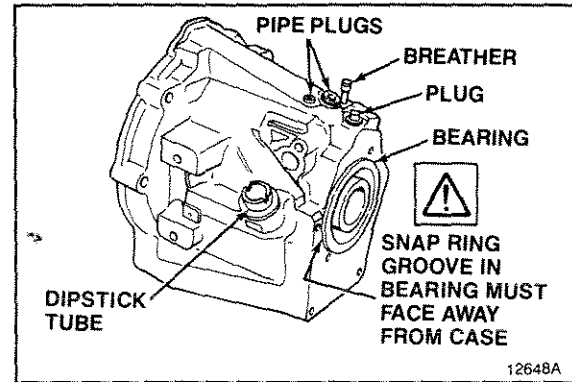

Case Assembly

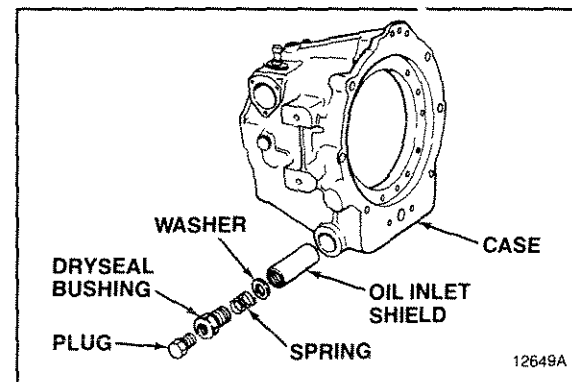

Oil Shield Assembly

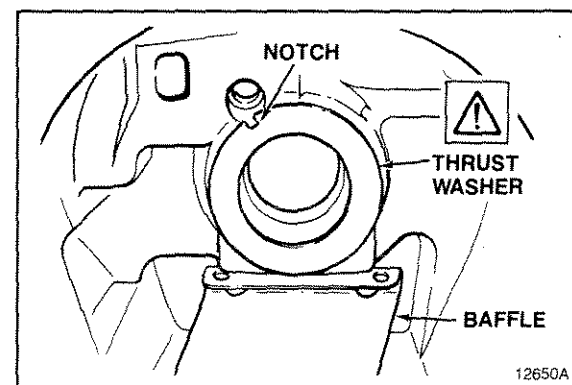

Thrustwasher and Baffle Installation

STEP 4. Lubricate sealing rings (83) and bushings (84) with vasoline.

If removed, press bushings (84) into pinion carrier (85).



CAUTION: Do not block pressure holes in pinion carrier (85) with bushings (84).

Install sealing rings (83) in grooves of pinion carrier (85). Compress each sealing ring (83) until it locks in place.

Install pinion carrier (85) in case (98).

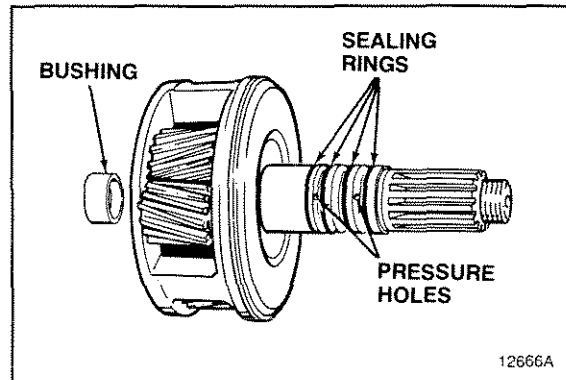

Pinion Carrier Assembly

STEP 5. Install pressure plate (74) in ring gear (76).

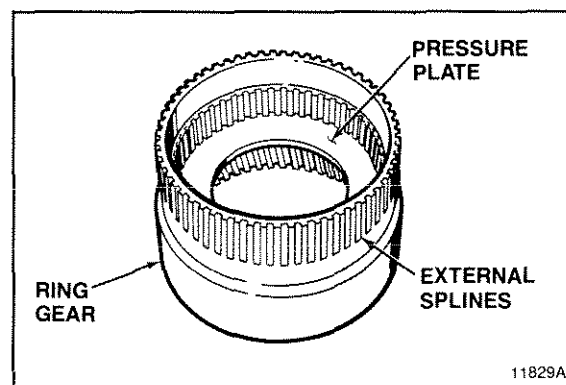

Pressure Plate Assembly

STEP 6. Starting with a friction clutch plate (73), alternately stack friction clutch plates (73) and steel clutch plates (72).

Place pressure plate (71) on top of clutch plates (72 and 73).

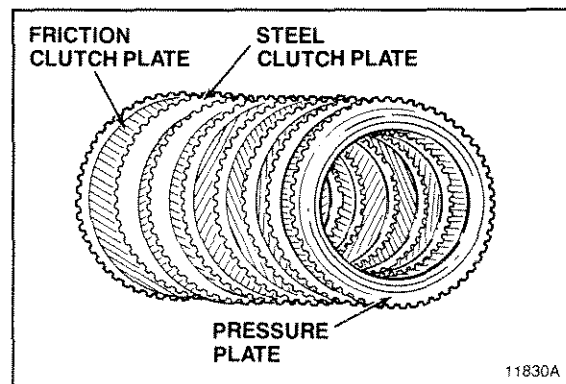

Forward Clutch Pack Arrangement

STEP 7. Install clutch plates (72 and 73) and pressure plate (71) in ring gear (76).

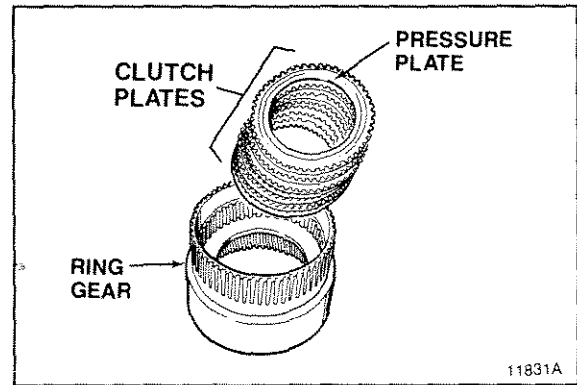

Forward Clutch Pack Assembly

STEP 8. Install snap ring (70) in ring gear (76).



CAUTION: Several different snap rings are used to assemble the clutch group. They have different thicknesses. Be sure the correct snap ring is used.

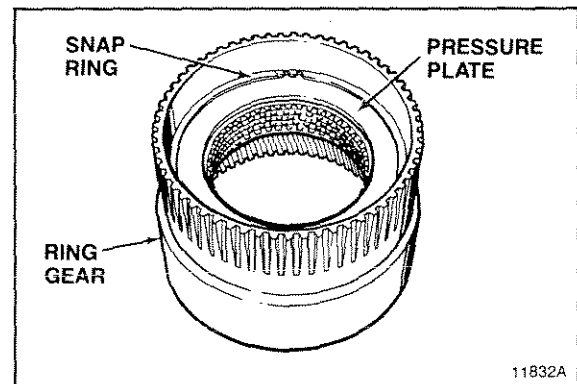

Snap Ring Installation

STEP 9. Lubricate O-ring (66) lightly with vasoline and install in groove of forward clutch cylinder (64).

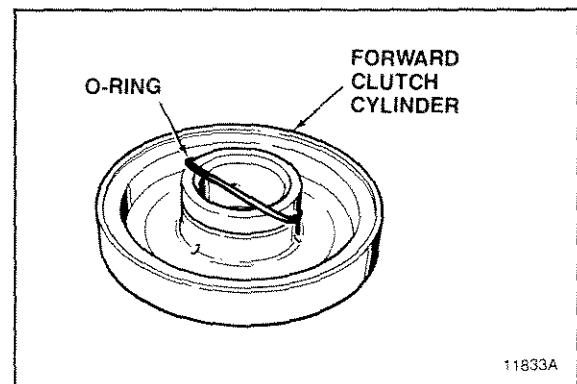

O-Ring Installation

STEP 10. Lubricate clutch spring bearing ring (68) and piston sealing ring (67) with vasoline.

Install clutch spring bearing ring (68) in groove on piston (65) face.

Install piston sealing ring (67) in outer groove of piston (65).

NOTE: Check that piston sealing ring (67) is not twisted, cut, or deformed. Replace if damaged.

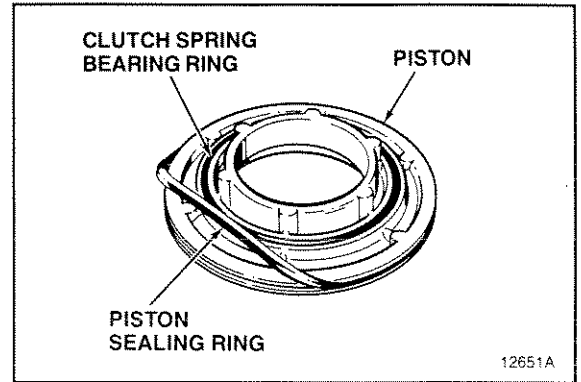

Clutch Rings Installation

STEP 11. Install piston (65) in forward clutch cylinder (64).

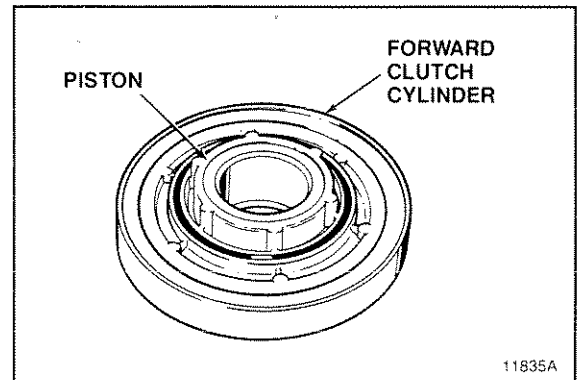

Piston Installation

STEP 12. Place clutch belleville (dish) spring (69) inside rim of forward clutch cylinder (64). Spring is dished. The inside of the spring should be lower than the outside.

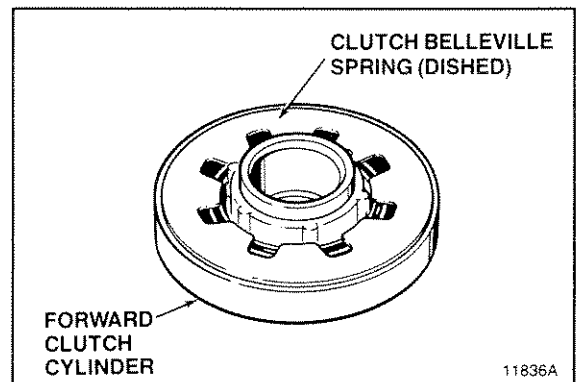

Clutch Spring Assembly

STEP 13. Install ring gear (76) over forward clutch cylinder (64), with piston (65) and spring (69) facing up. Press ring gear (76) down over forward clutch cylinder (64).



CAUTION: Check to see that clutch spring bearing ring (68) is still seated in the groove of clutch piston (65).

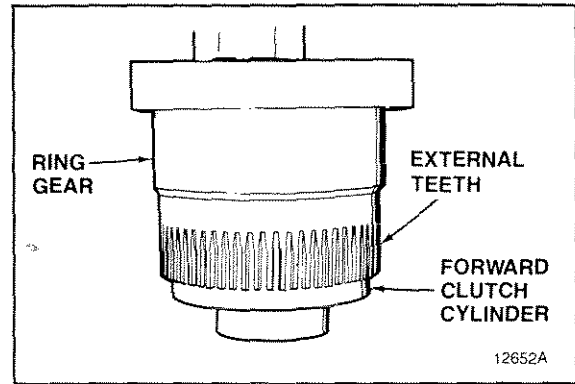

Forward Clutch Cylinder Installation

STEP 14. Remove clutch assembly from press. Install snap ring (60) in groove of ring gear (76).



CAUTION: Several different snap rings are used to assemble the clutch group. They have different thicknesses. Be sure the correct snap ring is used.

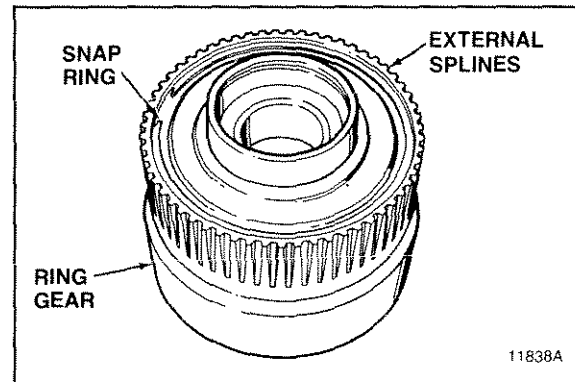

Snap Ring Installation

STEP 15. Place ring gear (76) in press with external splines facing down. Assembly tool should support the ring gear (76) only. The forward clutch cylinder (64) should not be touching the assembly tool. Press forward clutch cylinder (74) against snap ring (60). Remove clutch assembly from press.

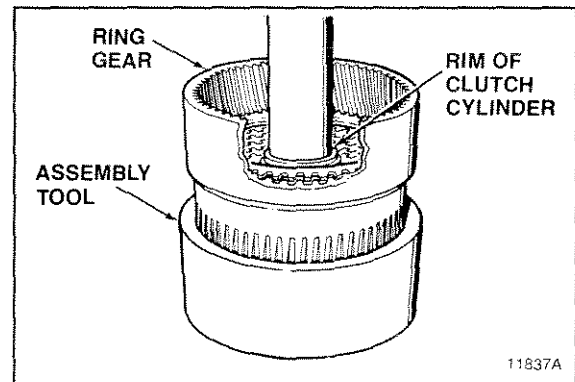

Compressing Clutch Pack

STEP 16. Push down, by hand, on clutch plates. Measure snap ring gap. Select proper thickness snap ring (75) or combination of snap rings (75), to set clutch pack clearance. Refer to chart below. More than one snap ring may be required.

Clearance for bronze pack (71C)- 0.018"-0.053"
 Clearance for bronze pack (72C)- 0.035"-0.055"
 Clearance for paper pack (71C)- 0.018"-0.053"
 Clearance for paper pack (72C)- 0.021"-0.046"

PART NUMBER	SNAP RING THICKNESS	
	in.	mm
4768	.050-.054	1.3-1.4
4768A	.074-.078	1.9-2.0
4768B	.096-.100	2.4-2.5
10-00-139-018	.062-.066	1.6-1.7
10-00-139-048	.033-.037	.84-.94
10-00-139-049	.050-.054	1.27-1.37

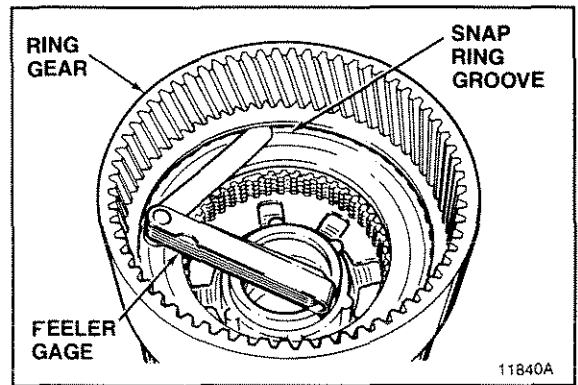

Snap Ring Selection

STEP 17. Install selected snap ring(s) (75) in groove of ring gear (76).

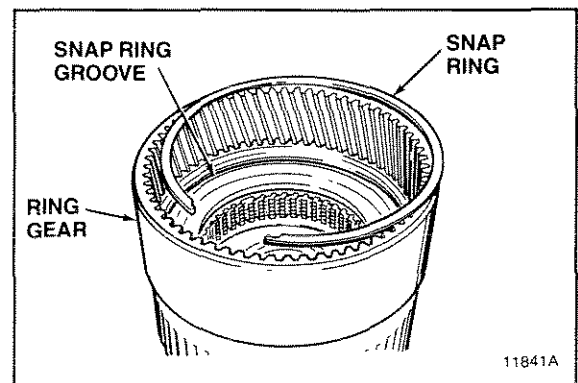

Snap Ring Assembly

STEP 18. If removed, install woodruff key (81) in drive gear assembly (82). Slide forward clutch hub (80) on drive gear assembly (82) and align with woodruff key (81). Press forward clutch hub (80) on drive gear assembly (82) and against shoulder.

Install snap ring (79) in groove of drive gear assembly (82).

Lubricate sealing rings (78) with vasoline and install in grooves of drive gear assembly (82).

Compress each sealing ring (78) until it locks in place.

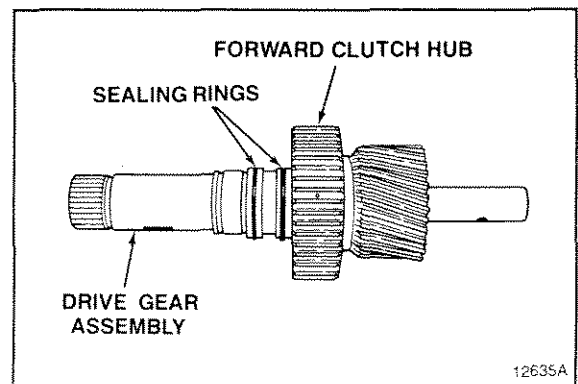

Sealing Ring Installation

STEP 19. Install drive gear assembly (82) in clutch assembly. Slide bearing (63) down drive gear assembly (82).

Place complete assembly in press. Press bearing (63) into drive gear assembly (82) until seated against shoulder.

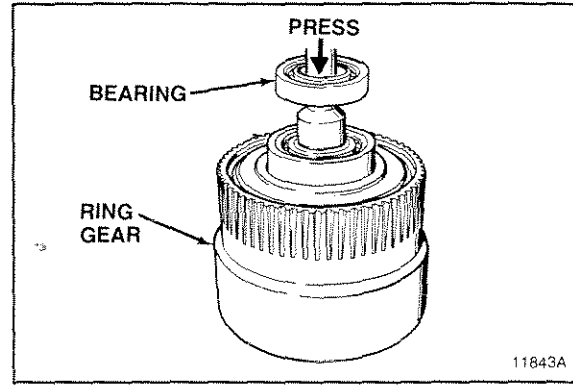

Bearing Installation

STEP 20. Install snap rings (61 and 62) in grooves of drive gear assembly (82) and forward clutch cylinder (64).

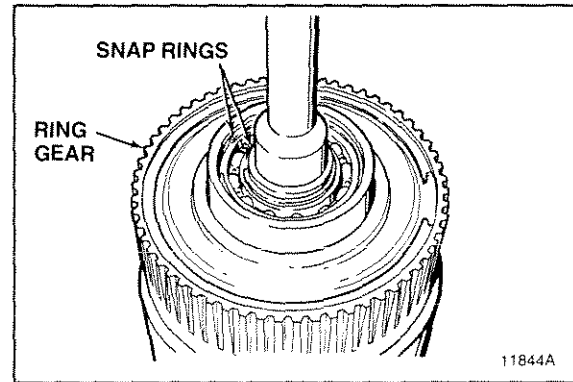

Snap Ring Installation

STEP 21. Apply vasoline to bronze thrustwasher (77). Install over end of shaft and against face of gear.

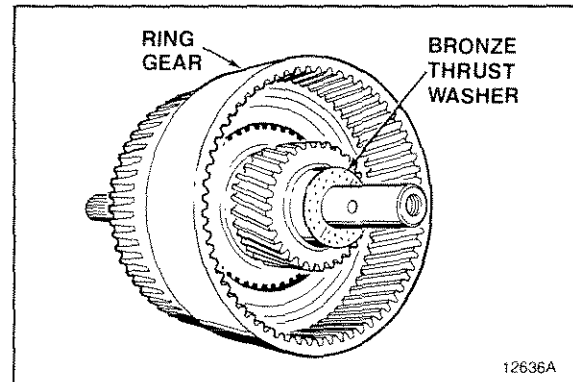

Thrustwasher Assembly

STEP 22. Install clutch and drive gear assembly (82) in case (98).

Rotate clutch and drive gear assembly (82) back and forth to engage ring gear teeth with pinion gear teeth.

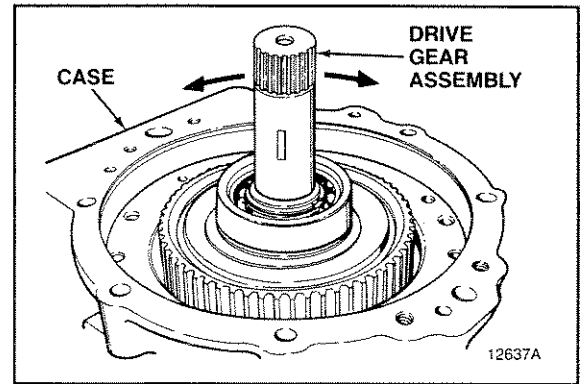

Clutch and Drive Gear Installation

STEP 23. If original case and clutch cylinder are used, install thrustwasher (59) on face of clutch cylinder.

On model 10-18 transmissions select new thrustwasher (59) as follows:

Position case vertically as shown. Measure from face of case (98), without gasket (49), to face of clutch cylinder.

When dimension is 0.433 inch (11.0 mm) or less, use 71-15B thrustwasher.

When dimension is greater than 0.433 inch (11.0 mm), use 10-16-193-001 thrustwasher.

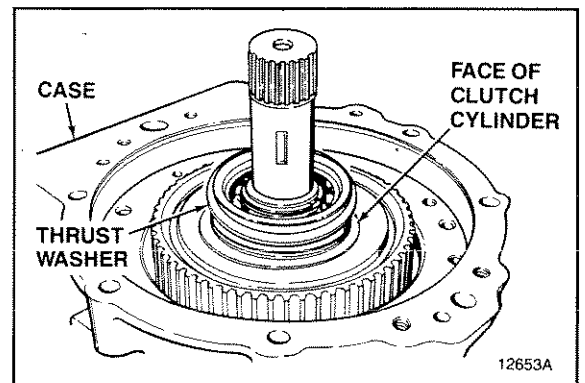

Thrustwasher Installation

STEP 24. Install one bronze reverse clutch friction plate (56) in case (98).

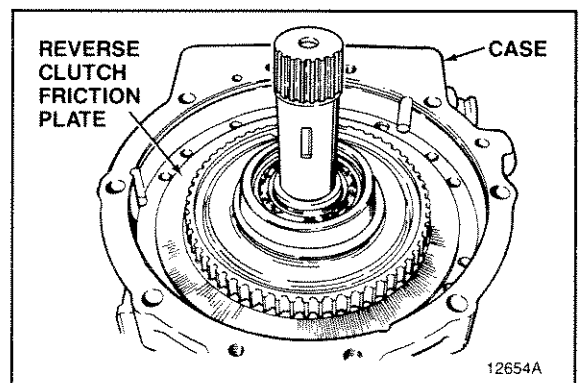

Friction Plate Installation

STEP 25. Install three dowel pins (58) and eleven pressure plate springs (57) in case (98).

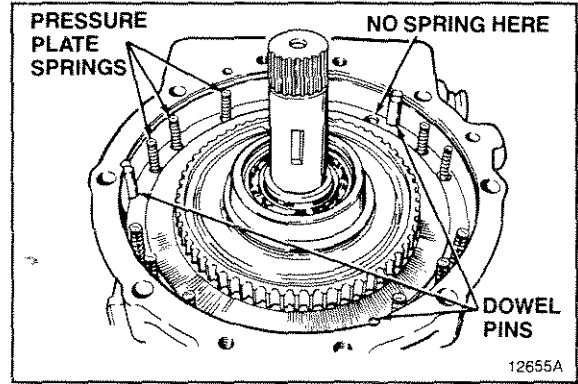

Spring and Dowel Pin Installation

STEP 26. Install one steel separator plate (55) in case (98) with large part of tab to left of dowel pin (58).

Alternately stack remaining reverse clutch friction plates (56) and steel separator plates (55) in case (98).

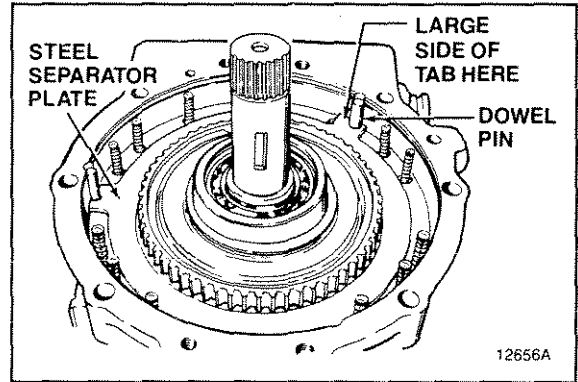

Reverse Clutch Pack Installation

STEP 27. Install reverse clutch pressure plate (54) in case (98) with three half moons aligned with dowel pins (58). Be sure all springs are seated in their holes.

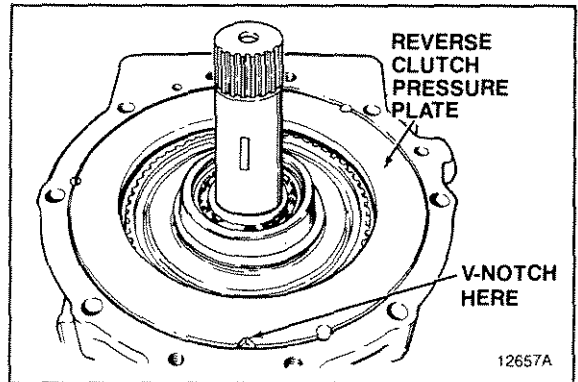

Pressure Plate Installation

STEP 28. Lubricate sealing ring (52) with vasoline and install in groove of reverse clutch piston (51).

NOTE: Be sure sealing ring (52) is not twisted, cut or distorted. Replace if damaged.

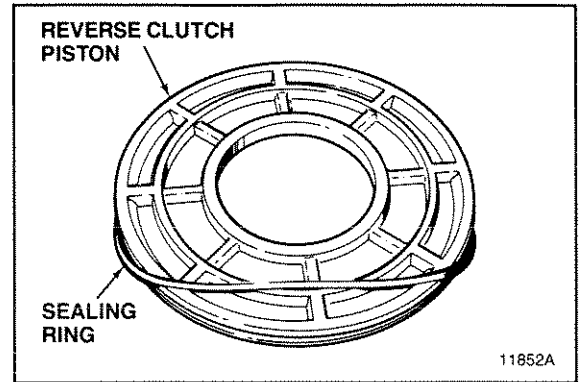

Sealing Ring Assembly

STEP 29. If removed, press needle bearing (48) into adapter (45). Needle bearing must be installed flush (even) with back face of adapter (45).

Lubricate O-ring (53) with vasoline and install in groove of adapter (45).

NOTE: Be sure O-ring (52) is not twisted, cut, or distorted. Replace if damaged.

If removed, install dryseal plug (50) in adapter (45).

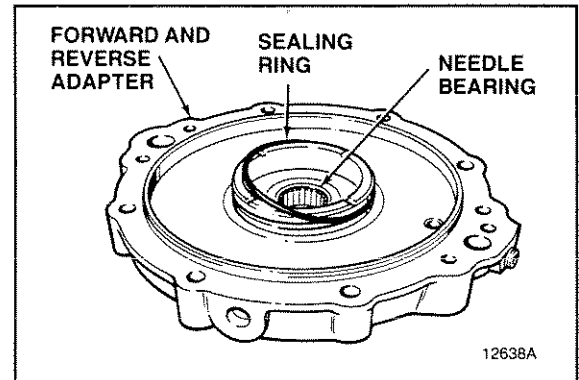

Sealing Ring Installation

STEP 30. Install reverse clutch piston (51) in adapter (45).

Lightly coat gasket (49) with vasoline and place on adapter (45).

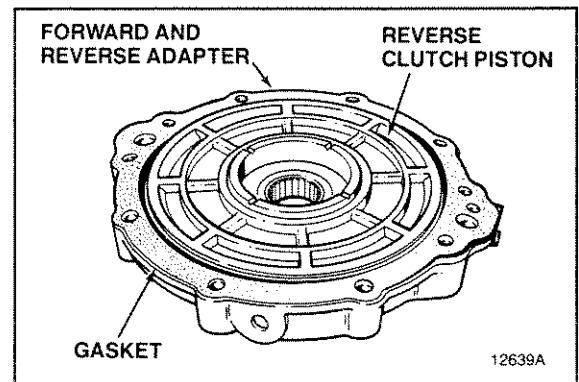

Reverse Clutch Piston Assembly

STEP 31. Install adapter (45) on case (98) and align bolt holes.

Thread four capscrews (46) into case (98). Tighten in a criss-cross pattern to final torque specified in Table 4.

Lightly tap woodruff key (44) into place in drive gear (82) with a soft-faced mallet.

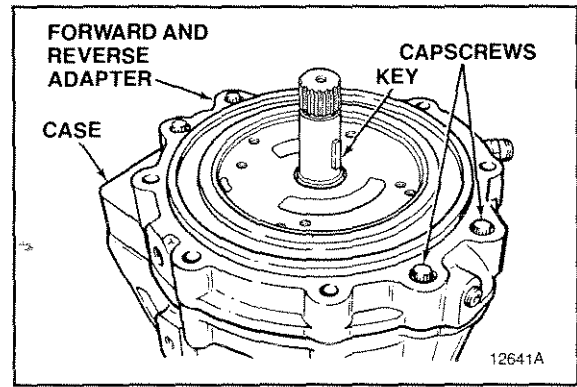

Adapter Installation

STEP 32. Press oil seal (42) into pump body.



CAUTION: Oil seal must be installed dry. Lubricants can damage rubber coating.

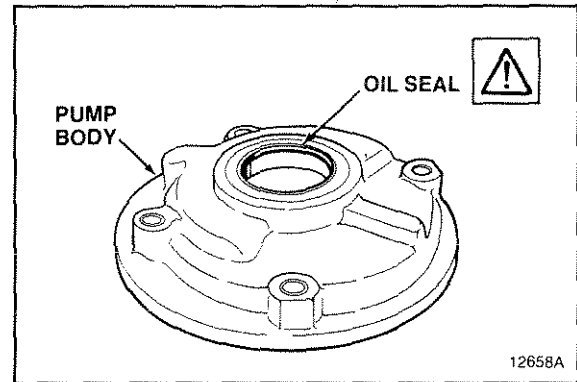

Oil Seal Installation

STEP 33. Install driven gear in pump body.

NOTE: Pump gear should be installed the same side down as removed.

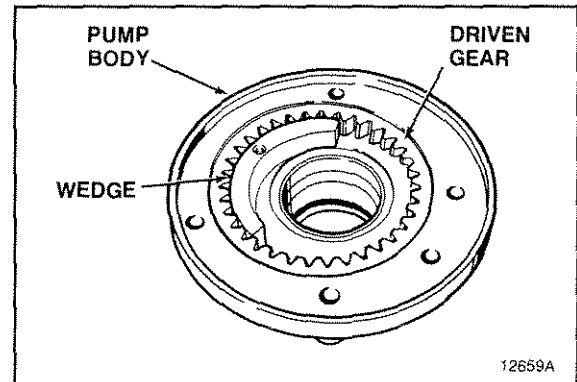

Pump Driven Gear Assembly

STEP 34. Lubricate pump gasket (43) with vasoline and install in groove of adapter (47).

Install pump drive gear onto input shaft (82). Check that pump drive gear locates freely on woodruff key (44) and shaft (82).

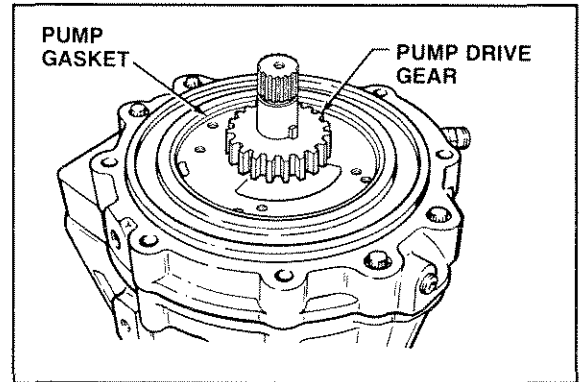

Pump Gasket Installation

STEP 35. Install pump assembly (40) on top of adapter (47) and align bolt holes.



CAUTION: Position pump housing with cast arrow at top pointing in the same direction as engine rotation.

Thread four bolts (41) into adapter (47). Tighten in a criss-cross pattern to final torque specified in Table 4.

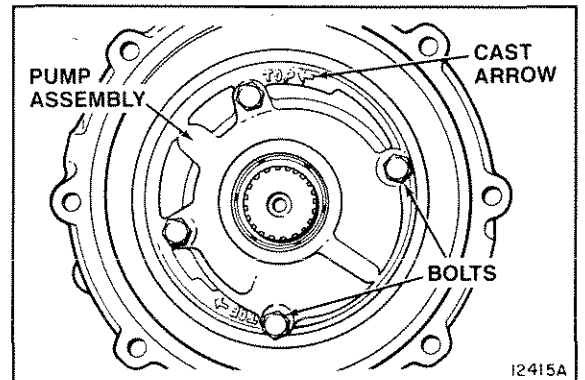

Pump Assembly Installation

STEP 36. Assemble control valve assembly (33). Refer to Figure 6.

Lubricate O-ring (38) with vasoline and install on end of valve assembly (33).

NOTE: Gap in snap ring must be aligned with notch in control valve.

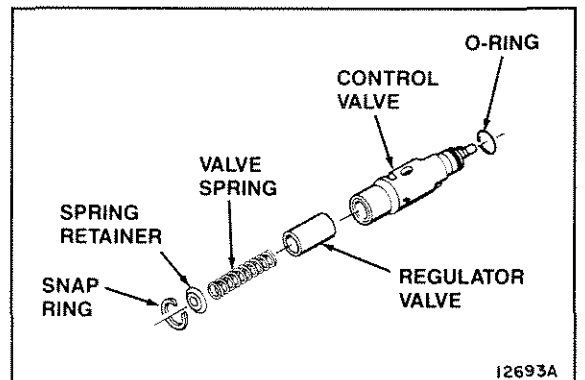

Valve Assembly

STEP 37. Lubricate control valve O.D. Slide control valve assembly (33) into side of case (98).

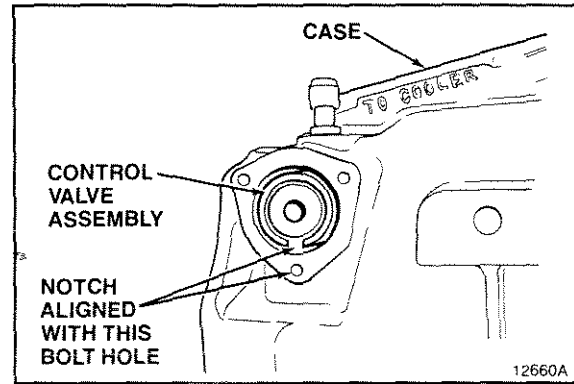

Valve Assembly Installation

STEP 38. Install switch cam (31) on end of valve assembly (33). Be sure tab on switch cam (31) sets in notch of valve assembly (33).

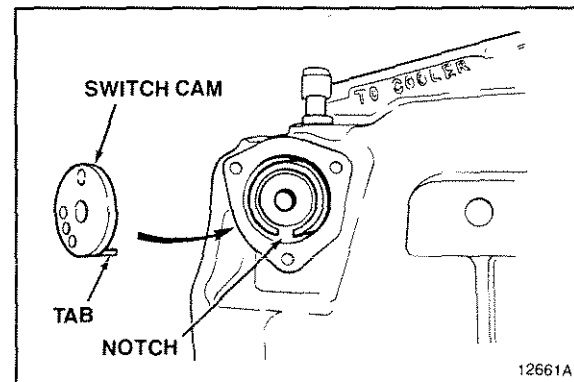

Switch Cam Installation

STEP 39. Install valve cover (28) as follows:

Position gasket (31) on case (98). Place valve cover (28) over gasket (32) and align bolt holes.

Thread three bolts (29) and lockwashers (30) into case (98). Tighten bolts in a criss-cross pattern to final torque specified in Table 4.

If removed, lubricate O-ring (27) with vasoline and install in groove of neutral switch (26). Thread neutral switch assembly (25) into valve cover (28) and tighten to torque specified in Table 4.

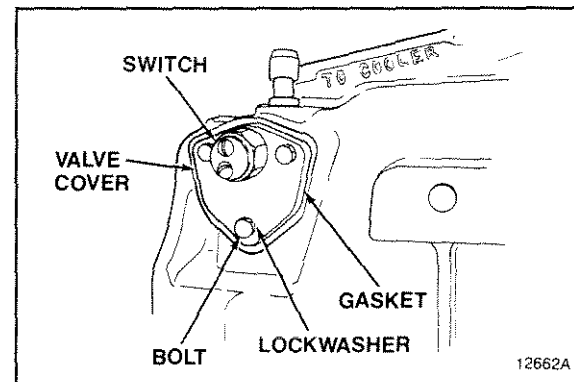

Valve Cover Installation

STEP 40. Install shift lever (19) as follows:

Lubricate poppet spring (24) and hole in case (98) with grease, shell alvania #2 or equivalent. Place poppet spring (24) and steel ball (23) in case (98).

Slide shift lever (19) over end of control valve assembly (33) and against steel ball (23). Rotate shift lever (19) to engage steel ball (23) in hole of shift lever (19).

Hold shift lever (19) against steel ball (23). Install washers (21 and 22) and thread nut (20) on control valve assembly (33). Tighten nut (20) to torque specified in Table 4.

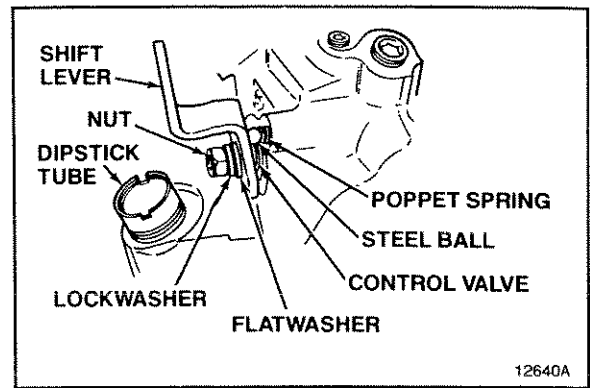

Shift Lever Assembly

STEP 41. Install bearing retainer (3) as follows:

If removed, press oil seal (6) into bearing retainer (3).



CAUTION: Oil Seal must be installed dry. Lubricants can damage rubber coating.

Install gasket (8) and bearing retainer (3) on back of case (98). Thread bolts (4) and lockwashers (5) into case (98). Tighten bolts (4), in a criss-cross pattern, to torque shown in Table 4.

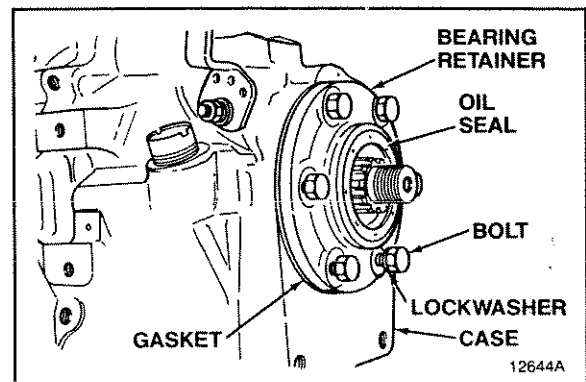

Bearing Retainer

STEP 42. Slide coupling (2) on output shaft. Thread nut (1) on output shaft. Tighten nut (1) to torque shown in Table 4.

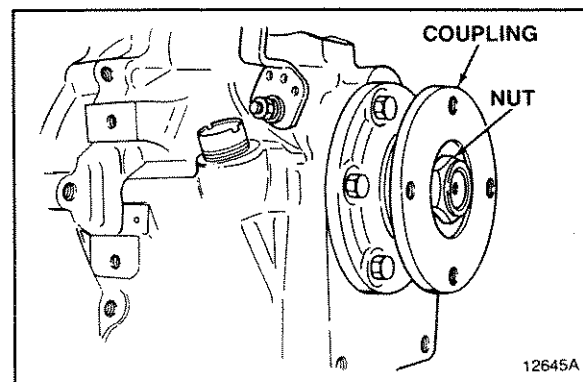

Coupling Installation

STEP 43. Install dipstick (17) in side of case (98). Turn handle until snug. Do not overtighten.

NOTE: For assembly of reduction units refer to the sections in the back of this manual.

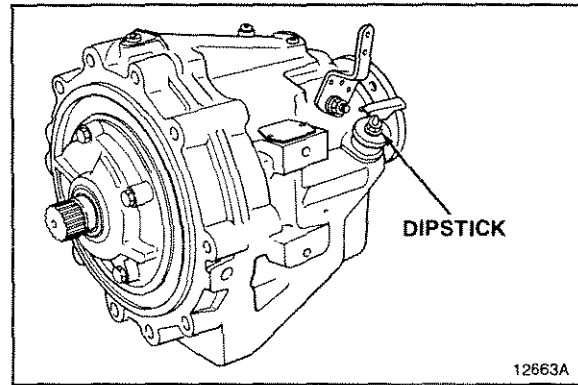

Dipstick Installation

INSTALLATION



CAUTION: After a transmission failure the cooler and cooler lines must be flushed to remove contaminated hydraulic fluid and metal/rubber particles. Failure to comply can result in premature wear or failure of overhauled transmission.

- Align input shaft spline with damper plate.
- Assemble transmission to engine, and then install bolts. Do not use bolts to draw transmission against engine.



WARNING: CHECK THE SHIFT LEVER AT THE HELM TO SEE THAT FORWARD POSITION IS ALSO FORWARD POSITION AT THE TRANSMISSION SHIFT LEVER. (TRANSMISSION SHOULD NOT BE RUNNING IN REVERSE WHEN BOAT IS GOING FORWARD.)

- Adjust the shift cable so the holes in the shift lever are centered over the detent ball at each selector location. See Figure 7A.
- Read OEM manual for complete installation instructions. Installation literature is available from Borg-Warner Automotive-Transmission Systems. Request Form No. 1131.
- Connect oil line to oil to the cooler outlet. See Figure 7B.

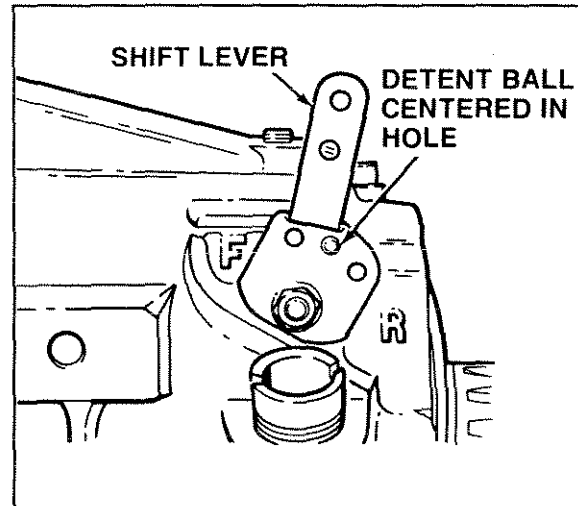

Figure 7A. Shift Cable Adjustment

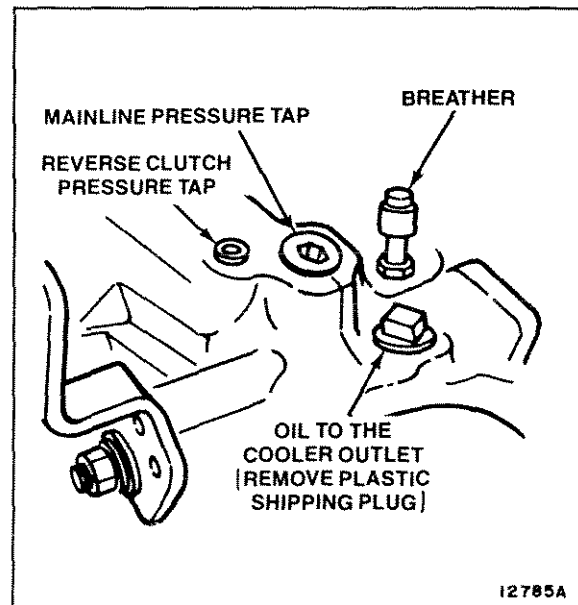
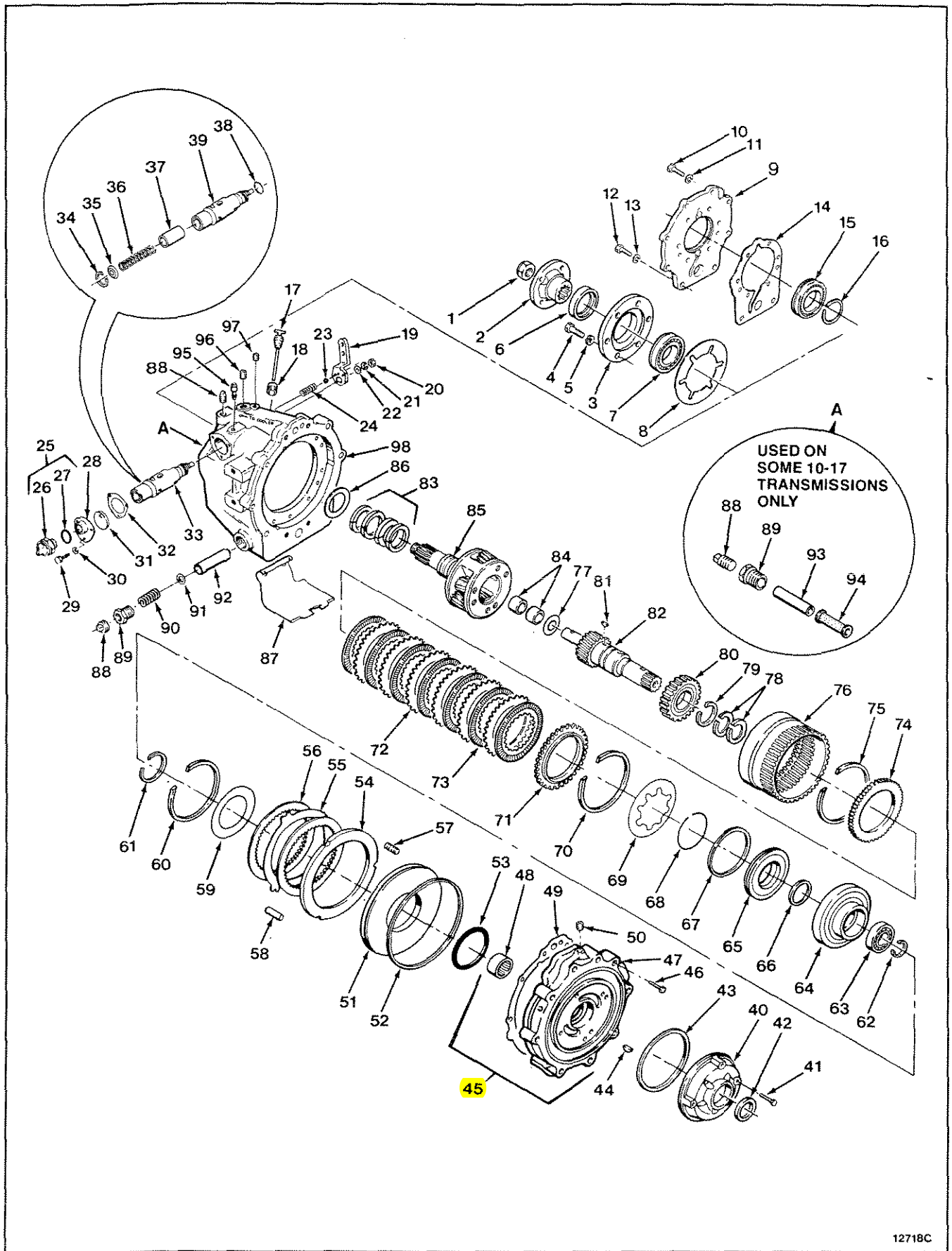

Figure 7B. Oil to Cooler Outlet



12718C

Figure 8. 71C and 72C Transmission Assembly - Current Production

INDEX NO.	PART NUMBER	DESCRIPTION	QTY
Fig. 8	10-17-000-*	TRANSMISSION ASSEMBLY (MODEL 71C)	
	10-18-000-*	TRANSMISSION ASSEMBLY (MODEL 72C)	
1	4775L	• OUTPUT SHAFT NUT	1
2	4547BA	• COUPLING (10-17 ONLY)	1
2A	4547AY	• COUPLING (10-18 ONLY)	1
3	71-7	• BEARING RETAINER (10-17 ONLY)	1
3A	72-7	• BEARING RETAINER (10-18 ONLY)	1
4	0000179859	• HEX HEAD BOLT ($\frac{7}{16}$ -14 x 1- $\frac{1}{4}$) (10-17 ONLY)	6
4A	10-00-183-043	• HEX HEAD BOLT ($\frac{7}{16}$ -14 x 1- $\frac{1}{4}$) (10-18 ONLY)	6
5	0000103322	• LOCKWASHER ($\frac{7}{16}$) (10-17 ONLY)	6
6	71C-110	• OIL SEAL	1
7	B111AG	• BEARING (1 Pkg)	1
7A	B308AGS	• BEARING (10-17)	1
7B	B309AGS	• BEARING (10-18)	1
8	71-147	• BEARING RETAINER GASKET (10-17 ONLY)	1
8A	72-147	• BEARING RETAINER GASKET (10-18 ONLY)	1
9	**	• ADAPTER	1
9A	**	• ADAPTER	1
9B	**	• ADAPTER	1
10	**	• LOCK BOLT ($\frac{7}{16}$ -14 x $\frac{7}{8}$)	6
11	**	• LOCKWASHER ($\frac{7}{16}$) (10-18 ONLY)	6
11A	**	• LOCKWASHER ($\frac{7}{16}$) (10-17 ONLY)	6
i2	**	• HEX HEAD BOLT ($\frac{7}{16}$ -14 x 1- $\frac{3}{4}$)	2
13	**	• LOCKWASHER ($\frac{7}{16}$)	2
14	**	• ADAPTER GASKET	1
15	**	• BEARING	1
16	**	• RETAINING RING	1
17	10-17-559-001	• DIPSTICK (ALL DIRECT DRIVES EXCEPT -015 AND -016)	1
17A	10-13-559-001	• DIPSTICK (FOR -015 AND -016)	1
18	10-04-034-002	• DIPSTICK TUBE	1
19	71-79B	• SHIFT LEVER	1
20	9418892	• HEX NUT ($\frac{5}{16}$ -24)	1
21	0000108579	• LOCKWASHER ($\frac{5}{16}$)	1
22	0000103340	• FLATWASHER ($\frac{5}{16}$)	1
23	0000453632	• STEEL BALL ($\frac{5}{16}$)	1
24	71-42	• POPPET SPRING	1
25	10-00-640-004	• NEUTRAL SWITCH ASSEMBLY	1
26	NO NUMBER	• • NEUTRAL SWITCH (NSS)	1
27	10-00-141-046	• • O-RING	1
28	10-16-039-001	• • VALVE COVER	1
29	0000179796	• HEX HEAD BOLT ($\frac{1}{4}$ -20 x $\frac{1}{2}$)	3
30	0000103319	• LOCKWASHER ($\frac{1}{4}$)	3
31	10-16-039-001	• SWITCH CAM	1
32	71-14	• VALVE COVER GASKET	1
33	71-A244A	• CONTROL VALVE ASSEMBLY	1
34	4821	• • SNAP RING	1
35	71-246	• • SPRING RETAINER	1
36	71-242	• • VALVE SPRING	1
37	71-243	• • REGULATOR VALVE	1
38	4804H	• • O-RING	1

* REFER TO ASSEMBLY NUMBER ON ID TAG (See Figure 1)

** REFER TO REDUCTION SECTION IN BACK OF MANUAL.

NSS - NOT SERVICED SEPARATELY, BUY NEXT HIGHER ASSEMBLY

INDEX NO.	PART NUMBER	DESCRIPTION	QTY
39	71-244A	• • CONTROL VALVE	1
40	71C-A60	• PUMP ASSEMBLY	1
41	10-00-183-021	• HEX HEAD BOLT (5/16-18 x 1-3/8)	4
42	10-00-044-014	• • OIL SEAL	1
43	3-61	• PUMP GASKET	1
44	4873	• WOODRUFF KEY	1
45	71C-A8	• FORWARD AND REVERSE ADAPTER ASSEMBLY	1
46	4911	• CAPSCREW (3/8-16 x 1-1/4)	4
47	NO NUMBER	• • FORWARD AND REVERSE ADAPTER (NSS)	1
48	4840D	• • NEEDLE BEARING	1
49	71-144B	• GASKET	1
50	0000444858	• PIPE PLUG (1/4)	1
51	71-35	• REVERSE CLUTCH PISTON	1
52	4805A	• CLUTCH SEALING RING	1
53	4804G	• O-RING	1
54	71-71	• REVERSE CLUTCH PRESSURE PLATE	1
55	72-176	• STEEL CLUTCH PLATE	0-2
56	72-A66B	• FRICTION CLUTCH PLATE	1-3
57	71-97	• PRESSURE PLATE SPRING	11
58	71-87A	• DOWEL PIN (.312 DIA x .438 LONG)	3
58A	R6-177	• DOWEL PIN (.312 DIA x .621 LONG)	3
58B	4622E	• DOWEL PIN (.312 DIA x .875 LONG)	3
59	71-15B	• THRUSTWASHER	1
59A	10-16-193-001	• THRUSTWASHER	1
60	4822	• SNAP RING	1
61	R6A-7 1/2	• SNAP RING (10-17 ONLY)	1
61A	4766B	• SNAP RING (10-18 ONLY)	1
62	4734	• SNAP RING (10-17 ONLY)	1
62A	4559A	• SNAP RING (10-18 ONLY)	1
63	B107A	• BEARING (10-17 ONLY)	1
63A	B108A	• BEARING (10-18 ONLY)	1
64	71-70	• FORWARD CLUTCH CYLINDER (10-17 ONLY)	1
64A	72-70	• FORWARD CLUTCH CYLINDER (10-18 ONLY)	1
65	10-16-124-001	• FORWARD CLUTCH PISTON	1
65A	71-45	• FORWARD CLUTCH PISTON	1
66	5M-122	• O-RING	1
67	5L-36	• PISTON SEALING RING	1
68	5C-33	• CLUTCH SPRING BEARING RING	1
69	3-37	• CLUTCH BELLEVILLE SPRING	1
70	4755	• SNAP RING	1
71	5C-175A	• CLUTCH PRESSURE PLATE	1
72	3-176	• STEEL CLUTCH PLATE (10-17 ONLY)	4
72A	3-176	• STEEL CLUTCH PLATE (10-18 ONLY)	6
73	5C-A66A	• FRICTION CLUTCH PLATE (10-17 ONLY)	5
73A	5C-A66A	• FRICTION CLUTCH PLATE (10-18 ONLY)	7
74	5L-67	• CLUTCH PRESSURE PLATE	1
75	10-00-139-048	• SNAP RING (.033-.037 THICK) (10-17 ONLY) (Yellow)	1
75A	10-00-139-049	• SNAP RING (.050-.054 THICK) (10-17 ONLY) (Pink)	1
75B	4768	• SNAP RING (.050-.054 THICK) (10-18 ONLY) (Green)	1-2
75C	4768A	• SNAP RING (.074-.078 THICK) (10-18 ONLY) (Orange)	1
75D	4768B	• SNAP RING (.096-.100 THICK) (10-18 ONLY) (White)	1
75E	10-00-139-018	• SNAP RING (.062-.066 THICK) (10-18 ONLY) (Purple)	1

NSS - NOT SERVICED SEPARATELY, BUY NEXT HIGHER ASSEMBLY.

INDEX NO.	PART NUMBER	DESCRIPTION	QTY
76	71-6	• RING GEAR (10-17 ONLY)	1
76A	72-6	• RING GEAR (10-18 ONLY)	1
77	71-17	• THRUSTWASHER	1
78	4806J	• SEALING RING	2
79	4495	• SNAP RING	1
80	71-40	• FORWARD CLUTCH HUB (10-17 ONLY)	1
80A	10-16-179-001	• FORWARD CLUTCH HUB (10-18 ONLY)	1
81	0000218211	• WOODRUFF KEY (10-17 ONLY)	1
81A	0000124553	• WOODRUFF KEY (10-18 ONLY)	1
82	71C-3A16	• DRIVE GEAR ASSEMBLY (10-17 ONLY)	1
82A	72C-2A16	• DRIVE GEAR ASSEMBLY (10-18 ONLY)	1
83	4806B	• SEALING RING	4
84	A4867DD (KIT)	• BUSHING	2
85	10-17-659-***	• PINION CARRIER ASSEMBLY (10-17 ONLY)	1
85A	10-18-659-***	• PINION CARRIER ASSEMBLY (10-18 ONLY)	1
86	71-159	• THRUSTWASHER (USE W/BUSHING STYLE CASE)	1
86A	10-17-193-001	• THRUSTWASHER (USE W/SEALING RING STYLE CASE)	1
87	71-140	• OIL BAFFLE	1
87A	71B-140	• OIL BAFFLE	1
88	10-00-191-002	• PLUG (3/8-18)	2
89	4885B	• DRYSEAL BUSHING (3/4-14)	1
90	5L-222	• SPRING	1
91	35-143	• FLAT WASHER	1
92	72C-98	• OIL INLET SHIELD	1
93	71C-84	• OIL RETURN TUBE	1
94	71C-A98	• OIL STRAINER ASSEMBLY	1
95	A4740G	• BREATHER	1
96	0000444866	• PIPE PLUG (3/8-18)	1
97	0000444687	• PIPE PLUG (1/8-27)	1
98	10-17-565-***	• CASE (10-17 ONLY)	1
98A	10-18-565-***	• CASE (10-18 ONLY)	1

*** CHECK MODEL CHART TO DETERMINE CORRECT PART NUMBER

NOTE: The following kits are available for the Model 71C and 72C transmissions. Index numbers shown match the index numbers on the exploded-view, Figure 8.

INDEX NO.	PART NUMBER	DESCRIPTION	QTY
	A4867AB	FORWARD CLUTCH PACK KIT (10-18 ONLY)	
71	5C-175A	• CLUTCH PRESSURE PLATE	1
72A	3-176	• STEEL CLUTCH PLATE	6
73A	5C-A66A	• FRICTION CLUTCH PLATE	7
74	5L-67	• CLUTCH PRESSURE PLATE	1

INDEX NO.	PART NUMBER	DESCRIPTION	QTY
71	A4867AE	FORWARD CLUTCH PACK KIT (10-17 ONLY)	
72	5C-175A	• CLUTCH PRESSURE PLATE	1
73	3-176	• STEEL CLUTCH PLATE	4
74	5C-A66A	• FRICTION CLUTCH PLATE	5
	5L-67	• CLUTCH PRESSURE PLATE	1

INDEX NO.	PART NUMBER	DESCRIPTION	QTY
6	A4867HA	OIL SEAL AND SEALING RING KIT	
38	71C-110	• OIL SEAL	1
42	4804H	• O-RING	1
43	10-00-044-014	• OIL SEAL	1
52	3-61	• PUMP GASKET	1
53	4805A	• CLUTCH SEALING RING	1
66	4804G	• O-RING	1
67	5M-122	• O-RING	1
78	5L-36	• CLUTCH SEALING RING	1
83	4806J	• SEALING RING	2
	4806B	• SEALING RING	4
	10-00-044-017	• OIL SEAL (REDUCTION UNITS ONLY)	1
	10-17-410-002	• SERVICE GASKET KIT (FOR CONTENTS SEE NEXT KIT LIST)	1

INDEX NO.	PART NUMBER	DESCRIPTION	QTY
8	10-17-410-002	SERVICE GASKET KIT	
8A	71-147	• BEARING RETAINER GASKET (10-17 ONLY)	1
14	72-147	• BEARING RETAINER GASKET (10-18 ONLY)	1
32	L4-146	• ADAPTER GASKET	1
49	71-14	• VALVE COVER GASKET	1
	71-144B	• GASKET	1
	L4-145	• GASKET (REDUCTION UNITS ONLY)	1
	L4-147	• GASKET (REDUCTION UNITS ONLY)	1

INDEX NO.	PART NUMBER	DESCRIPTION	QTY
25	10-04-420-052	NEUTRAL SWITCH KIT	
28	10-04-539-001	• SWITCH AND BODY ASSEMBLY	1
29	10-00-640-004	• • NEUTRAL SWITCH ASSEMBLY	1
30	10-16-039-001	• • VALVE COVER	1
31	0000179796	• HEX HEAD BOLT (1/4-20 x 1/2)	3
32	0000103319	• LOCKWASHER (1/4)	3
	10-16-099-001	• SWITCH CAM	1
	71-14	• VALVE COVER GASKET	1
	1340	• INSTRUCTION SHEET	1

INDEX NO.	PART NUMBER	DESCRIPTION	QTY
	10-95-410-002	SNAP RING SERVICE KIT	
15	4766	• RETAINING RING	1
34	4821	• SNAP RING	1
60	4822	• SNAP RING	1
61	R6A-7 ¹ / ₂	• SNAP RING (10-17 ONLY)	1
61A	4766B	• SNAP RING (10-18 ONLY)	1
62	4734	• SNAP RING (10-17 ONLY)	2
62A	4559A	• SNAP RING (10-18 ONLY)	1
70	4755	• SNAP RING	1
75	10-00-139-048	• SNAP RING (.033-.037 THICK)(10-17 ONLY) (Yellow)	1
75A	10-00-139-049	• SNAP RING (.050-.054 THICK)(10-17 ONLY) (Pink)	1
75B	4768	• SNAP RING (.050-.054 THICK)(10-18 ONLY) (Green)	2
75C	4768A	• SNAP RING (.074-.078 THICK)(10-18 ONLY) (Orange)	1
75D	4768B	• SNAP RING (.096-.100 THICK)(10-18 ONLY) (White)	1
75E	10-00-139-018	• SNAP RING (.062-.066 THICK)(10-18 ONLY) (Purple)	1
79	4495	• SNAP RING	1
	4756D	• SNAP RING (REDUCTION UNITS ONLY)	1
	4756E	• SNAP RING (REDUCTION UNITS ONLY)	1
	4816	• SNAP RING (REDUCTION UNITS ONLY)	1
	4766A	• SNAP RING (REDUCTION UNITS ONLY)	1

TRANSMISSION MODEL NUMBER	CASE ASSEMBLY NEW STYLE W/O BUSHINGS	CASE ASSEMBLY OLD STYLE W/BUSHINGS	FORWARD PINION CARRIER ASSEMBLY NEW STYLE W/SEALING RINGS	FORWARD PINION CARRIER ASSEMBLY OLD STYLE W/O SEALING RINGS	REDUCTION PINION CARRIER ASSEMBLY	REDUCTION HOUSING	THRUSTWASHER (If used between forward pinion carrier assy and case)
10-17-000-001	10-17-065-004	71B-1A	10-17-659-012	71-1A2	NOT USED	NOT USED	NOT USED
10-17-000-002	10-17-065-004	71B-1A	10-17-659-012	71-1A2	NOT USED	NOT USED	NOT USED
10-17-000-003	10-17-065-006	71C-1	10-17-659-012	71-1A2	NOT USED	NOT USED	NOT USED
10-17-000-004	10-17-065-006	71C-1	10-17-659-012	71-1A2	NOT USED	NOT USED	NOT USED
10-17-000-005	10-17-565-002	71-A1K	10-17-659-020	71-1A2A	L4-A150	10-17-065-001	10-17-193-001
10-17-000-006	10-17-565-002	71-A1K	10-17-659-020	71-1A2A	L4-A150	10-17-065-001	10-17-193-001
10-17-000-007	10-17-565-002	71-A1K	10-17-659-018	71-1A2C	L9-A150	10-17-065-003	NOT USED
10-17-000-008	10-17-565-002	71-A1K	10-17-659-018	71-1A2C	L9-A150	10-17-065-003	NOT USED
10-17-000-009	10-17-565-002	71-A1K	10-17-659-016	71-1A2B	10-17-659-006	10-17-065-002	10-17-193-001
10-17-000-010	10-17-565-002	71-A1K	10-17-659-016	71-1A2B	10-17-659-010	10-17-065-002	10-17-193-001
10-17-000-011	10-17-565-002	71-A1K	10-17-659-018	71-1A2C	10-17-659-007	10-17-065-001	NOT USED
10-17-000-012	10-17-565-002	71-A1K	10-17-659-018	71-1A2C	10-17-659-007	10-17-065-001	NOT USED
10-17-000-013	10-17-565-002	71-A1K	10-17-659-018	71-1A2C	10-17-659-008	10-17-065-001	NOT USED
10-17-000-014	10-17-565-002	71-A1K	10-17-659-018	71-1A2C	10-17-659-008	10-17-065-001	NOT USED
10-17-000-015	10-17-565-002	71-A1K	10-17-659-020	71-1A2A	NOT USED	NOT USED	10-17-193-001
10-17-000-016	10-17-565-002	71-A1K	10-17-659-020	71-1A2A	NOT USED	NOT USED	10-17-193-001
10-17-000-108	10-17-565-002	71-A1K	10-17-659-018	71-1A2C	10-17-659-021	10-17-065-003	NOT USED
10-18-000-001	10-18-565-001	72-A1J	10-18-659-006	72-1A2	NOT USED	NOT USED	NOT USED
10-18-000-002	10-18-565-001	72-A1J	10-18-659-006	72-1A2	NOT USED	NOT USED	NOT USED
10-18-000-003	10-18-565-002	72-A1K	10-18-659-014	10-18-659-002	L4-A150	10-17-065-001	10-17-193-001
10-18-000-004	10-18-565-002	72-A1K	10-18-659-014	10-18-659-002	L4-A150	10-17-065-001	10-17-193-001
10-18-000-005	10-18-565-002	72-A1K	10-18-659-012	72-1A2C	L9-A150	10-17-065-003	NOT USED
10-18-000-006	10-18-565-002	72-A1K	10-18-659-012	72-1A2C	L9-A150	10-17-065-003	NOT USED
10-18-000-007	10-18-565-002	72-A1K	10-18-659-010	72-1A2B	10-17-659-006	10-17-065-002	10-17-193-001
10-18-000-008	10-18-565-002	72-A1K	10-18-659-010	72-1A2B	10-17-659-010	10-17-065-002	10-17-193-001
10-18-000-009	10-18-565-002	72-A1K	10-18-659-012	72-1A2C	10-17-659-007	10-17-065-001	NOT USED
10-18-000-010	10-18-565-002	72-A1K	10-18-659-012	72-1A2C	10-17-659-007	10-17-065-001	NOT USED
10-18-000-011	10-18-565-002	72-A1K	10-18-659-012	72-1A2C	10-17-659-008	10-17-065-001	NOT USED
10-18-000-012	10-18-565-002	72-A1K	10-18-659-012	72-1A2C	10-17-659-008	10-17-065-001	NOT USED
10-18-000-013	10-18-565-002	72-A1K	10-18-659-014	10-18-659-002	NOT USED	NOT USED	10-17-193-001
10-18-000-014	10-18-565-002	72-A1K	10-18-659-014	10-18-659-002	NOT USED	NOT USED	10-17-193-001
10-18-000-015	10-18-565-002	72-A1K	10-18-659-008	72-1A2A	NOT USED	NOT USED	10-17-193-001
10-18-000-016	10-18-565-002	72-A1K	10-18-659-008	72-1A2A	NOT USED	NOT USED	10-17-193-001
10-18-000-017	10-18-565-001	72-A1J	10-18-659-006	72-1A2	NOT USED	NOT USED	NOT USED
10-18-000-106	10-18-565-002	72-A1K	10-18-659-012	72-1A2C	10-17-659-021	10-17-065-003	NOT USED

Model Chart 71C and 72C Transmissions

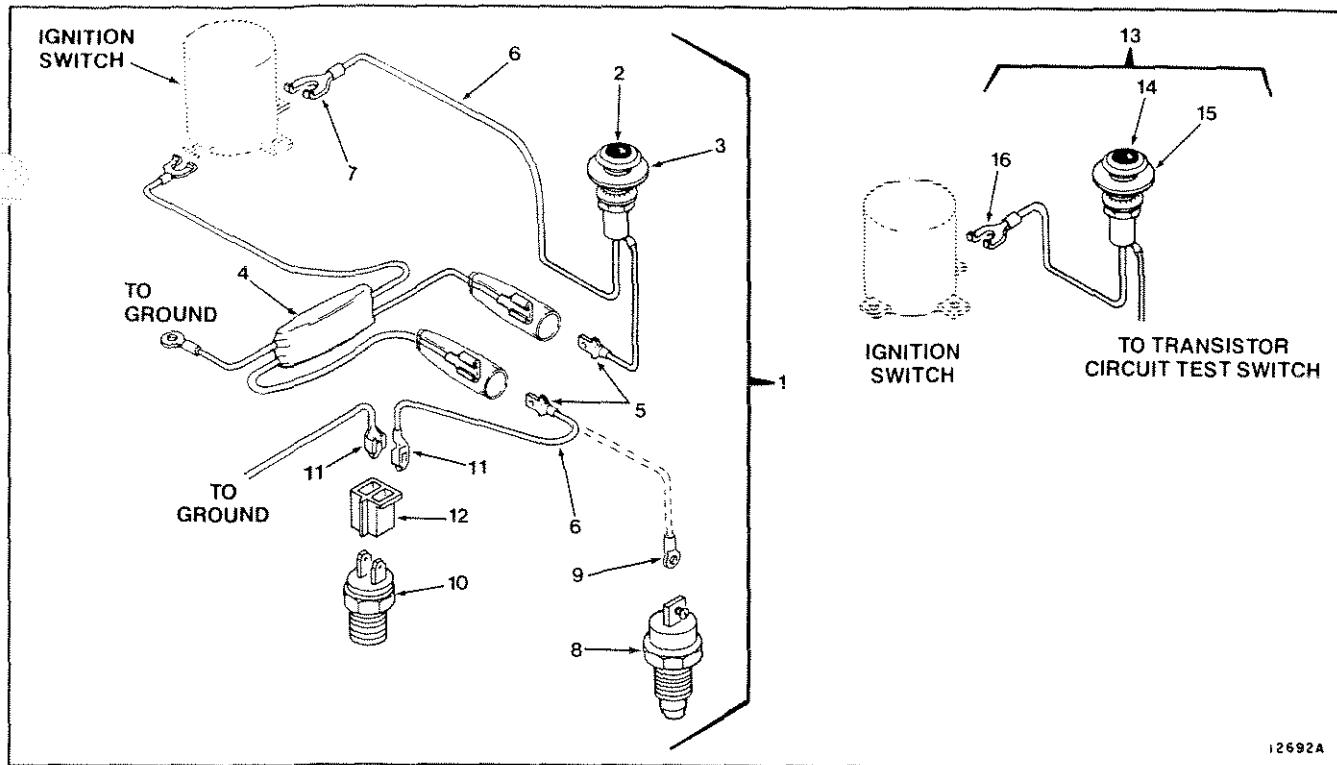

Figure 9. Optional Drive Gear Alarm Kits

INDEX NO.	PART NUMBER	DESCRIPTION	QTY
Fig. 9	NO NUMBER	OPTIONAL DRIVE GEAR ALARM KITS	
1	A4867HN	• DRIVE GEAR ALARM KIT	1
2	71C-309	• • PILOT LIGHT	1
3	71C-308	• • PLATE	1
4	71C-A312	• • TRANSISTOR CIRCUIT TEST SWITCH	1
5	4900E	• • 1/4" MALE TERMINAL	2
6	4927	• • INSTALLATION WIRE	1
7	4924	• • SPADE TERMINAL	1
8	71C-A102	• • TEMPERATURE SWITCH	1
9	4925	• • EYELET TERMINAL	1
10	10-00-140-004	• • TEMPERATURE SWITCH	1
11	10-00-140-005	• • FEMALE TERMINAL	2
12	10-00-140-006	• • FEMALE CONNECTOR	1
	71C-310	• • WIRING DIAGRAM	1
		• • INSTRUCTION SHEET	1
13	A4867HS*	• PILOT LIGHT KIT	1
14	71C-309	• • PILOT LIGHT	1
15	71C-308	• • PLATE	1
16	4924	• • SPADE TERMINAL	1
17	71C-310	• • WIRING DIAGRAM	1
		• • INSTRUCTION SHEET	1

* CAN BE PURCHASED TO ADD ANOTHER PILOT LIGHT TO THE DRIVE GEAR ALARM KIT. CAN NOT BE USED SEPARATELY.

SPECIFICATIONS



CAUTION: Threaded plugs, screws, bolts, and coupling nuts must be tightened to torque shown in this table to prevent premature failure of transmission or reduction unit.

Table 4. Bolt and Fastener Torques (Non-Lubricated)

PART NUMBER	DESCRIPTION	FT-LB	Nm
9418892	$\frac{5}{16}$ -24 Shift Lever Nut	8-11	11-15
0000179796	$\frac{1}{4}$ -20 x $\frac{1}{2}$ Hex Head Bolt	8-11	11-15
4775L	Coupling Nut	160-260	217-353
0000179859	$\frac{7}{16}$ -14 x 1- $\frac{1}{4}$ Hex Head Bolt	42-50	57-68
10-00-183-043	$\frac{7}{16}$ -14 x 1- $\frac{1}{4}$ Hex Head Bolt (Self Locking)	42-50	57-68
10-00-183-073	$\frac{7}{16}$ -14 x $\frac{7}{8}$ Lock Bolt	42-50	57-68
0000179864	$\frac{7}{16}$ -14 x 1- $\frac{3}{4}$ Hex Head Bolt	42-50	57-68
10-04-034-002	Dipstick Tube	10-40	14-55
10-00-183-021	$\frac{5}{16}$ -18 x 1 Hex Head Bolt	17-22	23-30
4911	$\frac{3}{8}$ -16 x 1- $\frac{1}{4}$ Capscrew	27-37	37-50
4885B	$\frac{3}{4}$ -14 Dryseal Bushing	25-35	34-48
0000444866	$\frac{3}{8}$ -18 Pipe Plug	17-27	23-37
0000444687	$\frac{1}{8}$ -27 Pipe Plug	7-12	9-16
10-00-640-004	$\frac{9}{16}$ -18 Switch Assembly	20-30	28-42
4853E	$\frac{7}{16}$ -14 x 1- $\frac{1}{4}$ Lock Bolt	42-50	57-68
0000179840	$\frac{3}{8}$ -18 x 1- $\frac{1}{8}$ Hex Head Bolt	27-37	37-50
4853B	$\frac{5}{16}$ -18 x $\frac{3}{4}$ Lock Bolt	17-22	23-30
4776BB	$\frac{7}{16}$ -14 x $\frac{7}{8}$ Lock Bolt	42-50	57-68
10-00-149-034	Coupling Nut	220-260	298-352

Table 5. Spring Dimensions

PART NUMBER	WHERE USED	APPROX. FREE LENGTH		APPROX. O.D.		DIAMETER OF WIRE		NO. OF ACTIVE COILS
		in.	mm	in.	mm	in.	mm	
71-242	Control Valve	2.66	67.6	0.78	19.8	0.14	3.6	12
71-42	Poppet	1.0	25.4	0.29	7.4	0.04	1.0	6
5L-222	Oil Inlet Shield	1.40	35.6	0.80	20.3	0.04	1.0	5
71-97	Pressure Plate	1.25	31.8	0.31	7.9	0.05	1.3	11

SPECIFICATIONS

(Continued)

Table 6. Test Pressures

PRESSURE TAP	ENGINE RPM	TYPICAL RANGE		TYPICAL RANGE	
		PSI	PSI	kPA	kPA
Neutral Line	600	115	135	793	931
	2000	NOT USED	NOT USED	NOT USED	NOT USED
	3500	NOT USED	NOT USED	NOT USED	NOT USED
Reverse Clutch	600	120	140	827	965
	2000	125	160	862	1103
	3500	NOT USED	NOT USED	NOT USED	NOT USED
Reverse Main Line	600	120	140	827	965
	2000	125	160	862	1103
	3500	NOT USED	NOT USED	NOT USED	NOT USED
Forward Main Line	600	115	140	793	965
	2000	125	160	862	1103
	3500	135	180	793	1241
		GPM	GPM	LPM	LPM
Reverse Cooler Flow	600	0	1.8	0	6.8
	2000	3.5	6.5	13.25	24.6
	3500	NOT USED	NOT USED	NOT USED	NOT USED
Forward Cooler Flow	600	0	1.8	0	1.8
	2000	3.5	8.0	13.25	30.3
	3500	6.0	10.5	22.7	39.7

NOTE: Pressures shown are typical at an oil temperature of 140 degrees F. Variations can occur due to plumbing, fittings, and cooler differences.

NOTE: Forward clutch feed does not have an external tap for checking pressure. When selector is in "F" position, line pressure indicates clutch pressure. Pressure drop from "N" to "F" indicates leakage in forward clutch circuit.

1.523:1 REDUCTION UNITS

A. DESCRIPTION

The 1.523:1 reduction unit is mounted on the back of a 71C or 72C transmission. The reduction unit output shaft rotates the same direction of the input shaft on the transmission. The output shaft rotates about one turn for every one and one half turns of the input shaft. Lubricating oil is supplied to the reduction unit through ports on the back of the transmission.

NOTE: For inspection, maintenance, and troubleshooting refer to the Table of Contents at the front of this manual.

B. OVERHAUL

The general overhaul information described on page 12 applies to these reduction units. Before starting disassembly, review the exploded-view shown in Figure 10. The reduction unit can be disassembled following the index numbers shown in Figure 10. The following procedures are correct for most reduction units. Minor differences may be found.



CAUTION: Threaded plugs, screws, bolts, and coupling nut must be tightened to torque shown in Table 4 to prevent premature reduction unit failure.

- A new coupling nut must be used at assembly.
- Do not disassemble the pinion carrier assembly unless damaged. The necessary tools must be available for proper assembly. Use the exploded view, Figure 10, for disassembly and assembly.
- The bearing cup and cone are a matched set. If one is damaged both must be replaced.
- A solid spacer is used to control rolling torque (end play). Rolling torque must be checked after assembly of the reduction unit, before assembly to the transmission.

NOTE: Early reduction units used a collapsible spacer. If this spacer must be replaced use the solid spacer.

NOTE: Early reduction units used a bearing retainer on the output shaft end of reduction housing. To order correct parts refer to exploded-view, Figure 11.

STEP 1. If removed, press bearing cone (23) on main shaft (21).

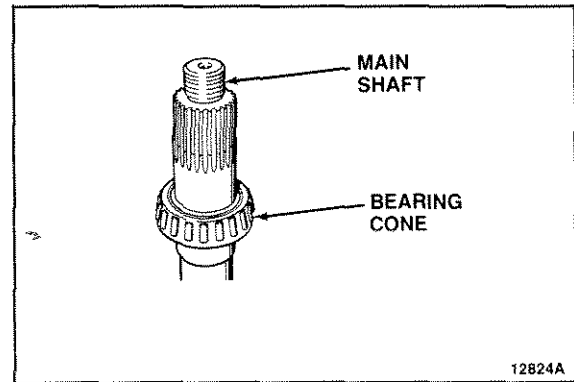

Bearing Cone Assembly

STEP 2. If removed, press bearing cups (24 and 29) into reduction housing (30).

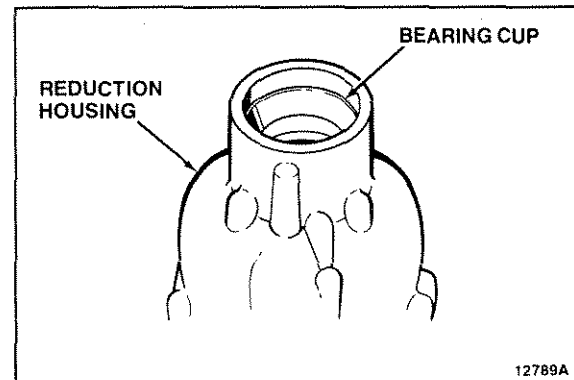

Bearing Cup Assembly

STEP 3. Install main shaft (21) in reduction housing (30).



CAUTION: If original spacer is not used the replacement spacer should be the same length. Using an incorrect size spacer can result in premature failure of reduction unit.

Support main shaft (21). Install original spacer (25) and bearing cone (28) in reduction housing (30).

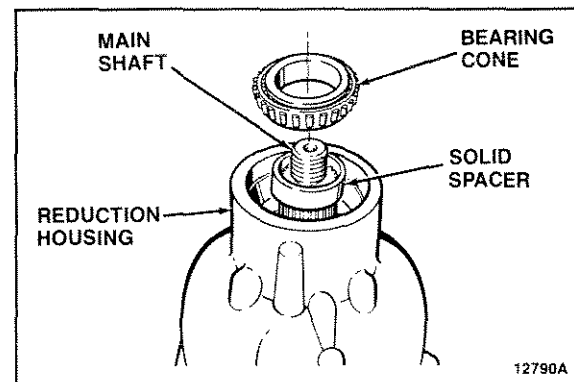

Spacer and Bearing Cone Assembly

STEP 4. Place reduction housing (30) in press with main shaft (21) supported. Press bearing cone (28) on main shaft (21). Remove reduction housing (30) from press.

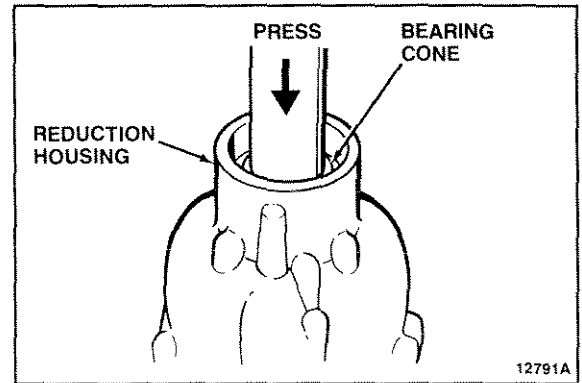

Bearing Cone Assembly

STEP 5. Install oil seal (26) in reduction housing (30). Outer surface of oil seal (26) should be flush with face of reduction housing (30).

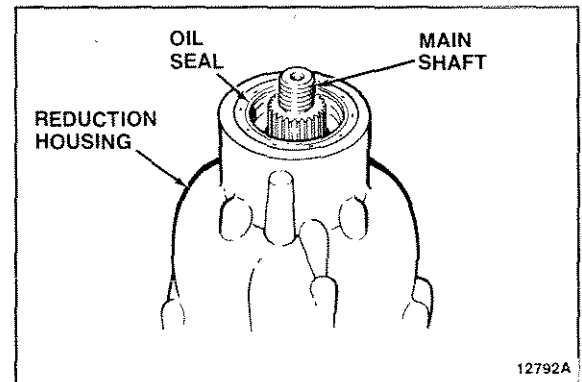

Oil Seal Assembly

STEP 6. Slide coupling (6) on main shaft (21). Thread nut (5) on main shaft (21). Tighten nut (5) to torque shown in Table 4.

Attach a torque wrench to nut (5). Turn torque wrench to check rolling torque of bearings (11 and 16). Rolling torque should be 5 to 30 in-lbs.

If rolling torque is over 30 in-lbs replace spacer (25) with a longer one. If rolling torque is under 5 in-lbs replace spacer (25) with a shorter one.

NOTE: Selection of the proper spacer (25) will result in 0 to 0.005 inch end play.

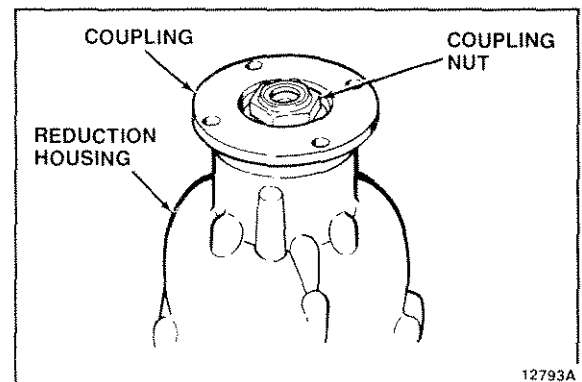

Coupling Assembly

STEP 7. Slide sun gear (20) into sun gear hub (21). Turn sun gear hub (21) over. Install snap ring (19) in groove of sun gear (20).

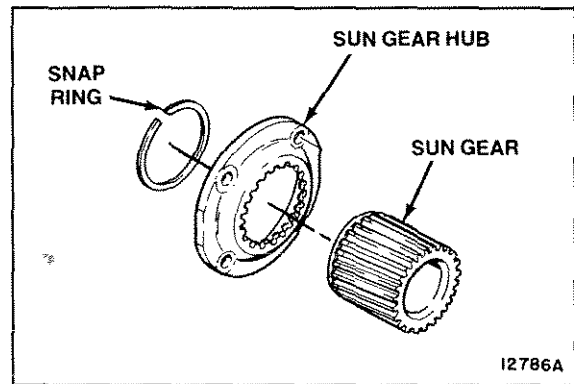

Sun Gear Assembly

STEP 8. Install sun gear (20) and sun gear hub (21) in reduction housing (30).

Thread four bolts (17) into reduction housing. Tighten bolts (17) to torque shown in Table 4.

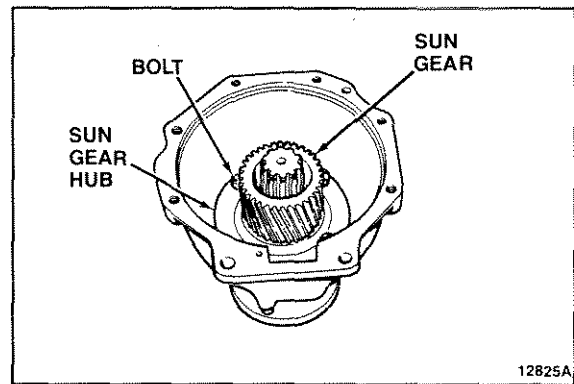

Sun Gear Installation

STEP 9. Install pinion carrier (8) in reduction housing (30). Install snap ring (7) in groove of main shaft (21).

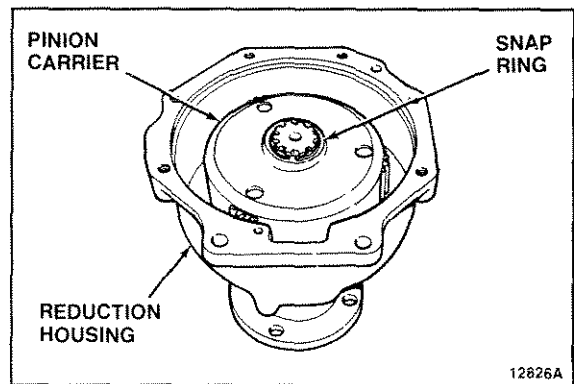

Pinion Carrier Installation

STEP 10. Install input gear (38) in ring gear (39).
Install snap ring (37) in groove of ring gear (39).

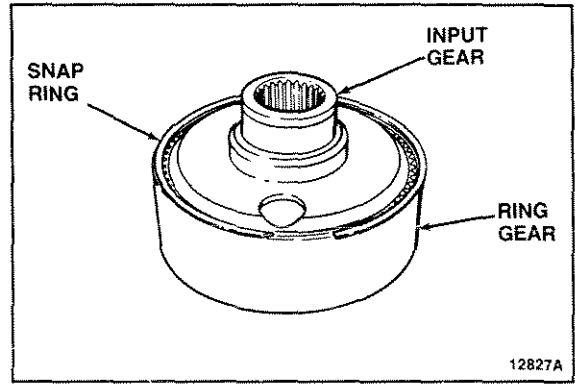

Input Gear Assembly

STEP 11. Install bearing (36) in reduction unit adapter (34). Snap ring groove in bearing (36) must be next to reduction unit adapter (34).

Press bearing (36) on input gear (38). Install snap ring (35) in groove of input gear (38).

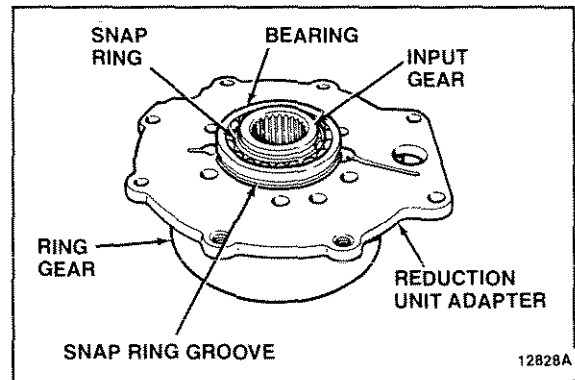

Reduction Unit Adapter Assembly

STEP 12. Lubricate front adapter gasket (40) with vasoline and install on transmission.

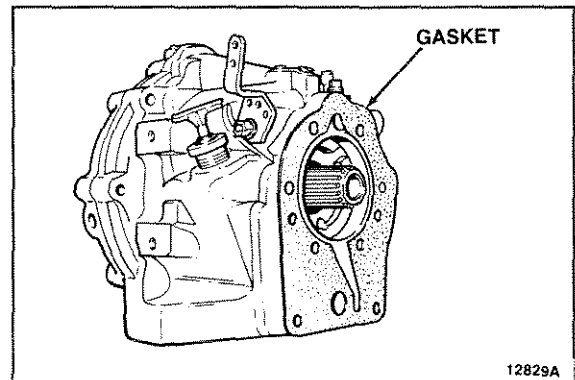

Front Adapter Gasket Installation

STEP 13. Install reduction unit adapter (34) on transmission.

Thread six bolts (32) with lockwashers (33) into transmission. Tighten bolts (32) in a criss-cross pattern to torque shown in Table 4.

NOTE: To install bolts (32) turn ring gear (39). This will align two holes in input gear (38) with reduction unit adapter (34).

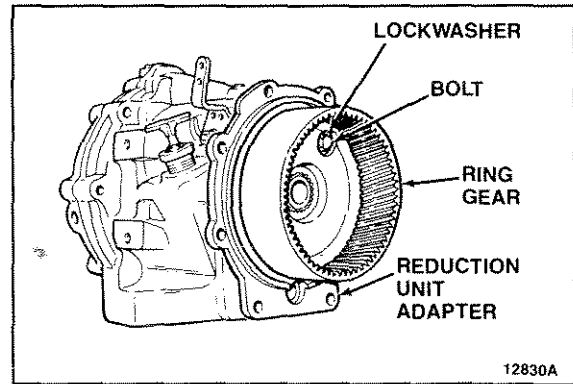

Reduction Unit Adapter Installation

STEP 14. Lubricate rear adapter gasket (31) with vasoline and install on reduction unit adapter (34).

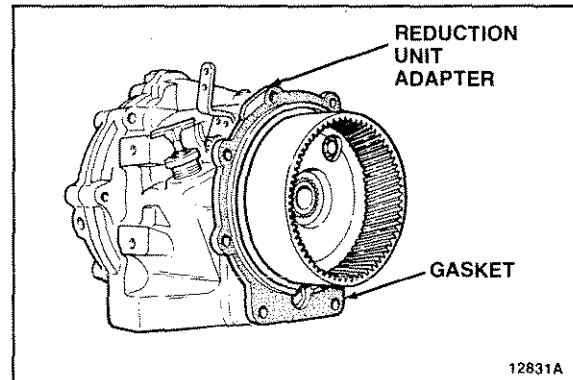

Rear Adapter Gasket Installation

STEP 15. Place reduction housing (30) on transmission. Turn coupling (6) to engage pinion gears (15) with ring gear (39).

Thread two bolts (1) with lockwashers (2) into transmission.

Thread six bolts (3) with lockwashers (4) into reduction housing (30).

Tighten bolts (1 and 3) in a criss-cross pattern to torque shown in Table 4.

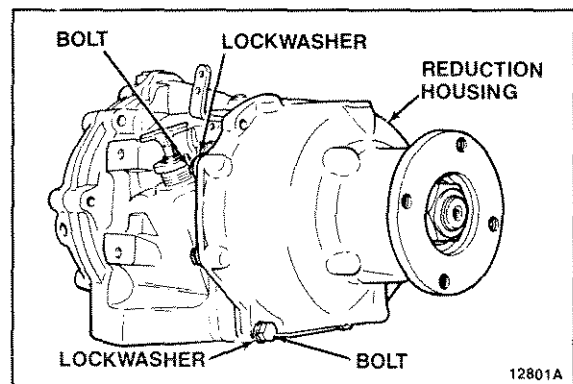

Reduction Housing Installation

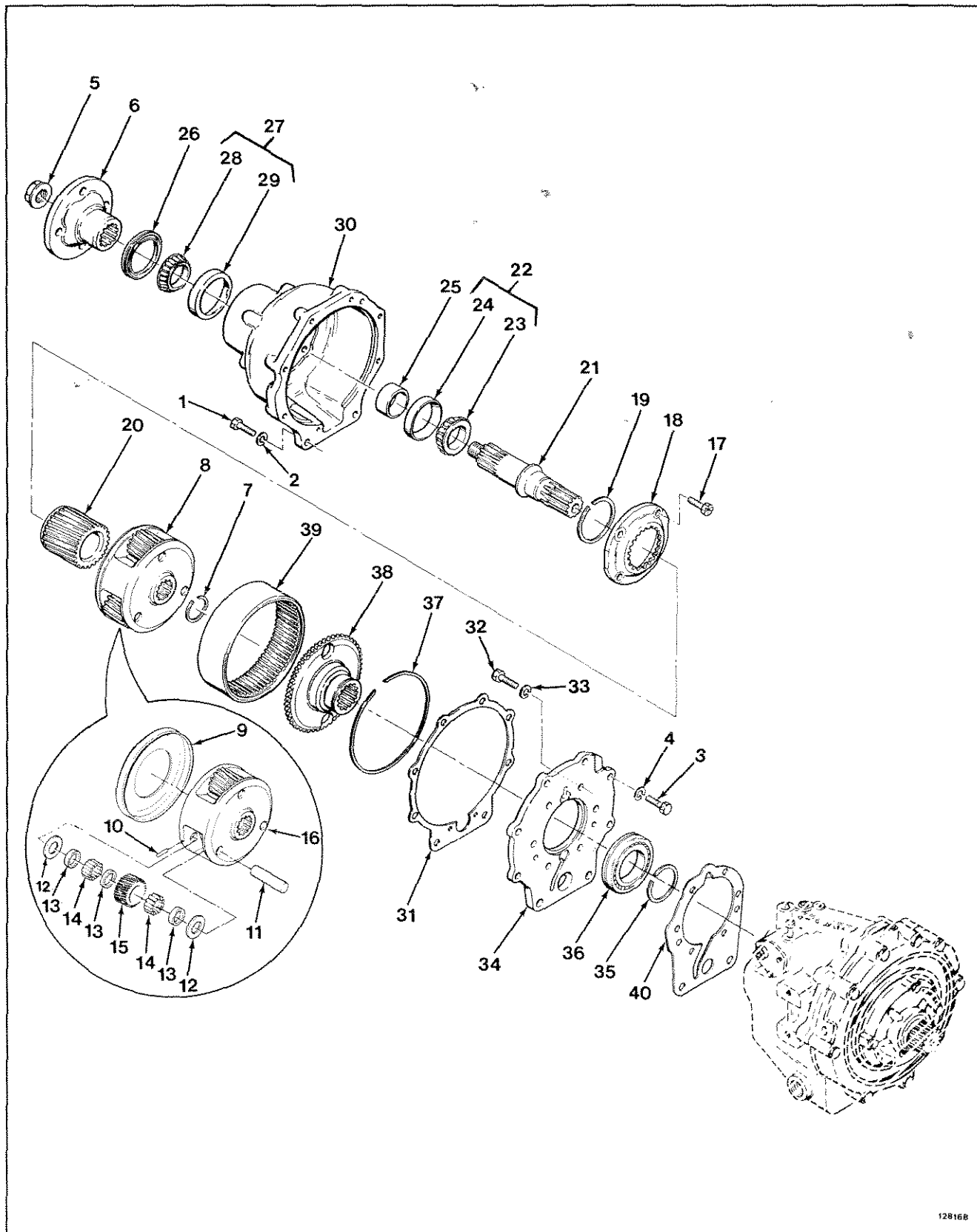

Figure 10. 1.523:1 Reduction Units - Current Production

INDEX NO.	PART NUMBER	DESCRIPTION	QTY
FIG. 10	NO NUMBER	REDUCTION UNIT ASSEMBLY (1.523:1)	
1	0000179864	• HEX HEAD BOLT (7/16-14 x 1-3/4)	2
2	0000103322	• LOCKWASHER (7/16)	2
3	0000179840	• HEX HEAD BOLT (3/8-18 x 1-1/8)	6
4	0000103321	• LOCKWASHER (3/8)	6
5	10-00-149-034	• COUPLING NUT	1
6	10-00-031-001	• COUPLING	1
7	4734	• SNAP RING	1
8	L4-A150	• PINION CARRIER ASSEMBLY	1
9	L4-135	• • OIL COLLECTOR RING	1
10	4717L	• • PINION SHAFT PIN	3
11	L5-39	• • PINION SHAFT	3
12	L3-43	• • PINION THRUSTWASHER	6
13	L3-41	• • PINION BEARING SPACER	9
14	4741A	• • ROLLER BEARING	144
15	L4-5	• • PINION GEAR	3
16	L4-150	• • PINION CAGE	1
17	4776BB	• LOCK BOLT (7/16-14 x 7/8)	4
18	10-17-179-001	• SUN GEAR HUB	1
19	10-00-139-013	• SNAP RING	1
20	10-17-165-001	• SUN GEAR	1
21	10-17-171-001	• MAIN SHAFT	1
22	NO NUMBER	• BEARING ASSEMBLY	1
23	10-00-133-010	• • BEARING CONE *	1
24	10-00-133-009	• • BEARING CUP *	1
25	10-17-053-002	• SOLID SPACER (.820-.821 INCH LONG)**	1
25A	10-17-053-003	• SOLID SPACER (.829-.830 INCH LONG)**	1
25B	10-17-053-004	• SOLID SPACER (.832-.833 INCH LONG)**	1
25C	10-17-053-005	• SOLID SPACER (.835-.836 INCH LONG)**	1
25D	10-17-053-006	• SOLID SPACER (.838-.839 INCH LONG)**	1
25E	10-17-053-007	• SOLID SPACER (.841-.842 INCH LONG)**	1
25F	10-17-053-008	• SOLID SPACER (.844-.845 INCH LONG)**	1
25G	10-17-053-009	• SOLID SPACER (.847-.848 INCH LONG)**	1
25H	10-17-053-010	• SOLID SPACER (.850-.851 INCH LONG)**	1
25I	10-17-053-011	• SOLID SPACER (.853-.854 INCH LONG)**	1
25J	10-17-053-012	• SOLID SPACER (.856-.857 INCH LONG)**	1
26	10-00-044-017	• OIL SEAL	1
27	NO NUMBER	• BEARING ASSEMBLY	1
28	10-00-133-002	• • BEARING CONE *	1
29	10-00-133-001	• • BEARING CUP *	1
30	10-17-065-001	• REDUCTION HOUSING	1
31	L4-146	• REAR ADAPTER GASKET	1
32	10-00-183-073	• LOCK BOLT (7/16-14 x 7/8)	6
33	0000103322	• LOCKWASHER (7/16)	6
34	L4-8B	• REDUCTION UNIT ADAPTER	1
35	4766	• SNAP RING	1
36	B111AG	• BEARING	1
37	4756D	• SNAP RING	1
38	L4-16	• INPUT GEAR	1
39	L3-6	• RING GEAR	1
40	L4-145	• FRONT ADAPTER GASKET	1

* REPLACE BOTH PARTS IF ONE IS DAMAGED.

** SELECT CORRECT SIZE SPACER AT ASSEMBLY. ONLY ONE REQUIRED.

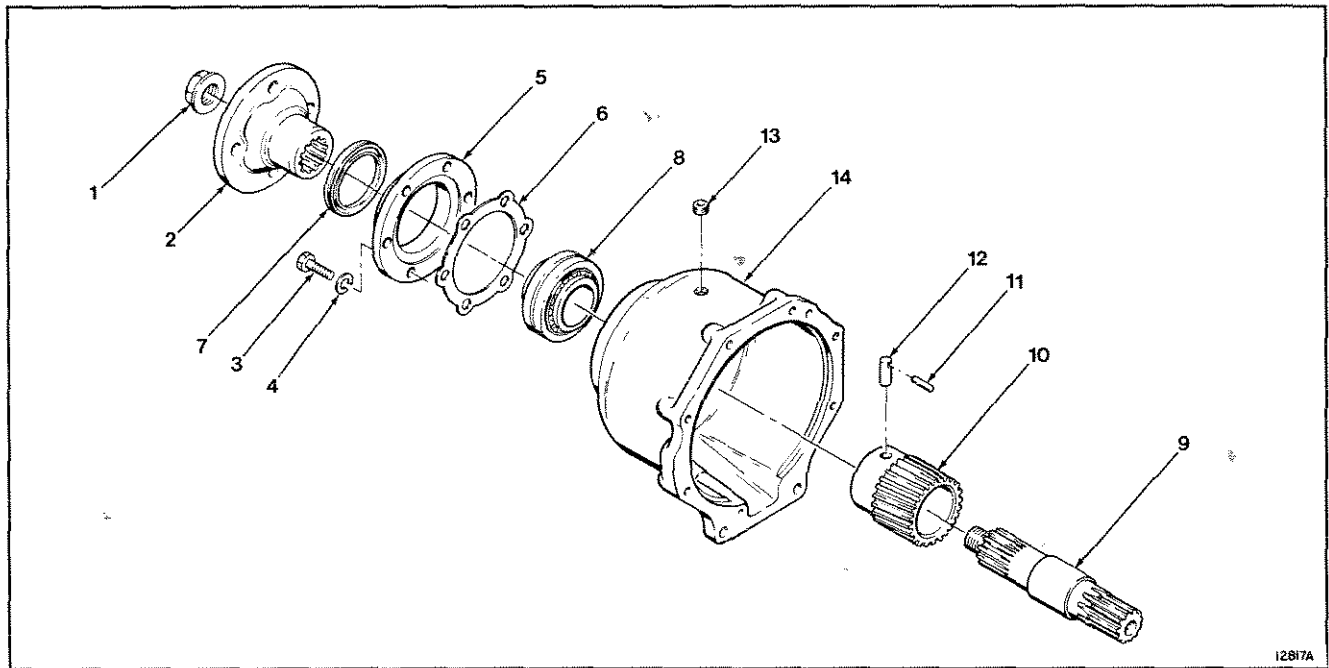

Figure 11. 1.523:1 Reduction Units - Early Production

INDEX NO.	PART NUMBER	DESCRIPTION	QTY
FIG. 11	NO NUMBER	REDUCTION UNIT	
1	4775L	• COUPLING NUT	1
2	4547AY	• COUPLING (72C ONLY)	1
2B	4547BA	• COUPLING (71C ONLY)	1
3	0000179860	• HEX HEAD BOLT (7/16-14 x 1-1/4)	6
4	0000103322	• LOCKWASHER (7/16)	6
5	L4-7	• BEARING RETAINER	1
6	L4-147	• BEARING RETAINER GASKET	1
7	71C-110	• OIL SEAL	1
8	4920A	• BEARING	1
9	L9-2	• MAIN SHAFT	1
10	L4-4	• SUN GEAR	1
11	4808	• SPRING PIN	1
12	L4-151	• PINION CAGE DRIVE PIN	1
13	103891	• EXPANSION PLUG	1
14	L4-1A	• REDUCTION HOUSING	1

NOTE: These early production parts are not interchangeable with current production parts in Figure 10. All other parts are the same.

1.88:1 AND 1.91:1 REDUCTION UNITS

A. DESCRIPTION

The 1.88:1 and 1.91:1 reduction units are mounted on the back of a 71C or 72C transmission. The reduction unit output shaft rotates the opposite direction of the input shaft on the transmission. The output shaft rotates about one turn for every two turns of the input shaft. Lubricating oil is supplied to the reduction unit through ports on the back of the transmission.

NOTE: For inspection, maintenance, and troubleshooting refer to the Table of Contents at the front of this manual.

B. OVERHAUL

The general overhaul information described on page 12 applies to these reduction units. Before starting disassembly, review the exploded-view shown in Figure 12. The reduction unit can be disassembled following the index numbers in Figure 12. The following procedures are correct for most reduction units. Minor differences may be found.

NOTE: Current Production 1.91:1 reduction units use a reduction unit adapter (39), lock plates (23), pinion carrier gasket (33), and o-ring (35) for noise reduction.



CAUTION: Threaded plugs, screws, bolts, and coupling nut must be tightened to torque shown in Table 4 to prevent premature reduction unit failure.

- A new coupling nut must be used at assembly.
- Do not disassemble the pinion carrier assembly unless damaged. The necessary tools must be available for proper assembly. Use exploded view, Figure 12, for disassembly and assembly.
- The bearing cup and cone are a matched set. If one is damaged both must be replaced.
- A solid spacer is used to control rolling torque (end play). Rolling torque must be checked after assembly of the reduction unit, before assembly to the transmission.

NOTE: Early 1.91:1 reduction units used a collapsible spacer. If this spacer must be replaced use the solid spacer.

NOTE: Early 1.91:1 reduction units used a bearing retainer on the output shaft end of reduction housing. To order correct parts refer to exploded-view, Figure 13.

STEP 1. If removed, press bearing cone (11) on to main shaft (8).

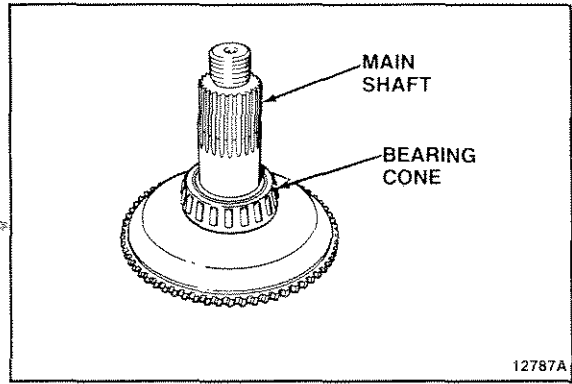

Bearing Cone Assembly

STEP 2. Install main shaft (8) in ring gear (9). Install snap ring (7) in groove of ring gear (9).

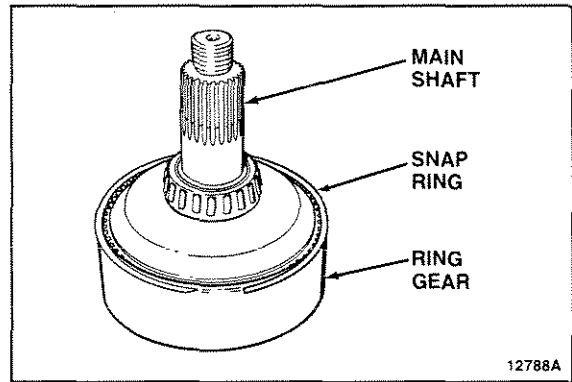

Main Shaft Assembly

STEP 3. If removed, press bearing cups (12 and 17) into reduction housing (18).

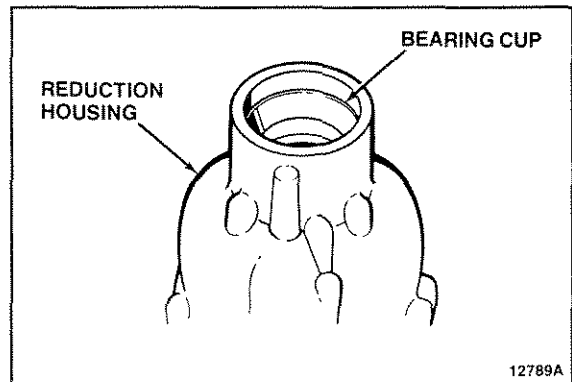

Bearing Cup Assembly

STEP 4. Install main shaft (8) and ring gear (9) in reduction housing (18).

Support ring gear (9). Install original spacer (13) and bearing cone (16) in reduction housing (18).



CAUTION: If original spacer is not used the replacement spacer should be the same length. Using an incorrect size spacer can result in premature failure of reduction unit.

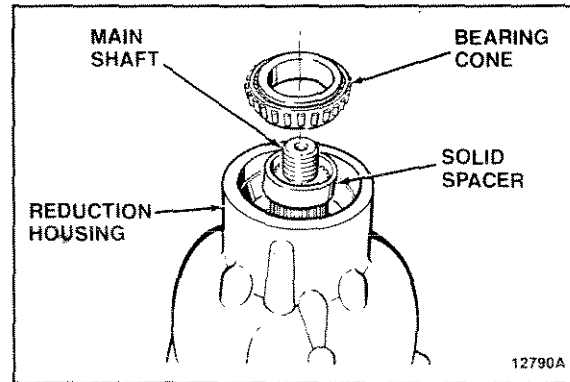

Spacer and Bearing Cone Assembly

STEP 5. Place reduction housing (18) in press with ring gear (9) supported. Press bearing cone (16) on main shaft (8). Remove reduction housing (18) from press.

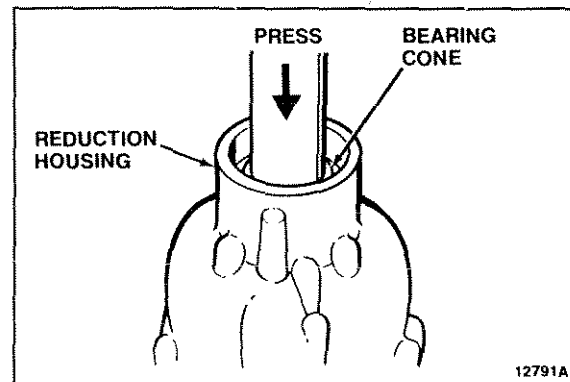

Bearing Cone Assembly

STEP 6. Install oil seal (14) in reduction housing (18). Outer surface of oil seal (14) should be flush with reduction housing (18) face.

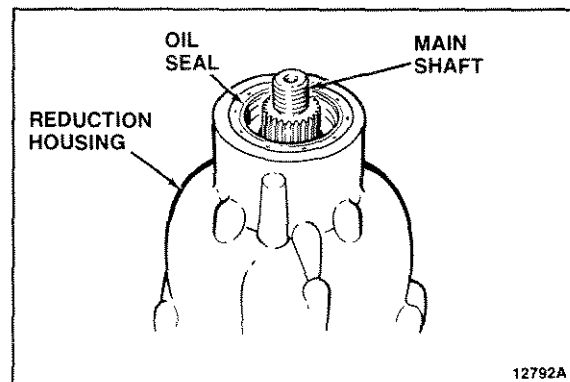

Oil Seal Assembly

STEP 7. Slide coupling (6) on main shaft (8). Thread nut (5) on main shaft (8). Tighten nut (5) to torque shown in Table 4.

Attach a torque wrench to nut (5). Turn torque wrench to check rolling torque of bearings (11 and 16). Rolling torque should be 5 to 30 in-lbs.

If rolling torque is over 30 in-lbs replace spacer (13) with a longer one. If rolling torque is under 5 in-lbs replace spacer (13) with a shorter one.

NOTE: Selection of the proper spacer (13) will result in 0 to 0.005 inch end play.

STEP 8. If removed, install bearing (41) and snap ring (40) in transmission.

Lubricate front adapter gasket (42) with vasoline and install on transmission.

STEP 9. Install reduction unit adapter (39) on transmission.

Thread six bolts (37) with lockwashers (38) into transmission. Tighten bolts (37) in a criss-cross pattern to torque shown in Table 4.

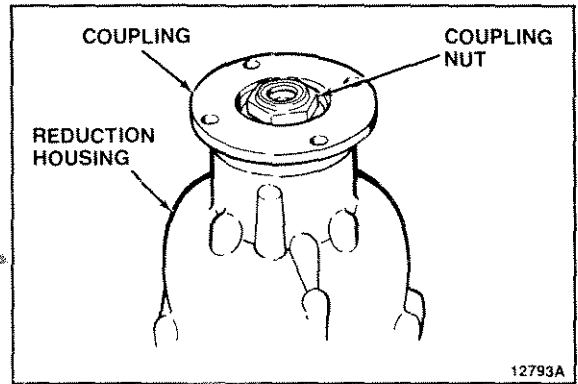

Coupling Assembly

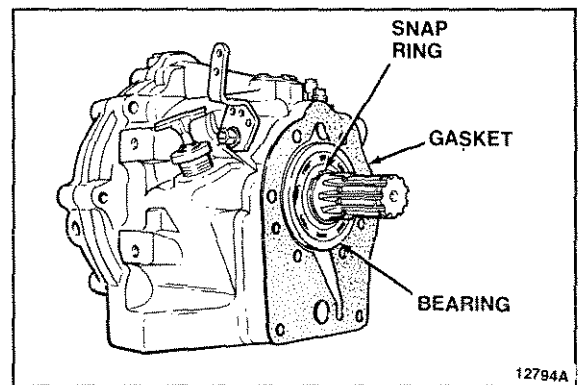

Front Adapter Gasket Installation

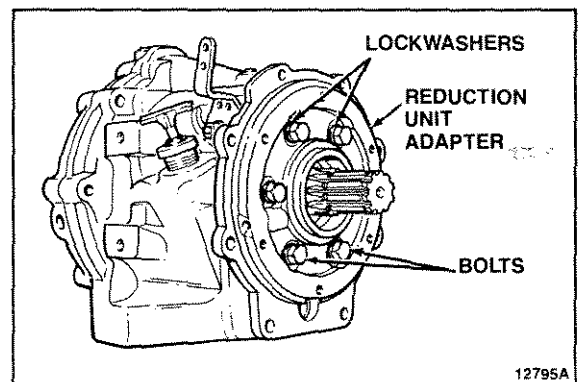

Reduction Unit Adapter Installation

STEP 10. For the 1.91:1 reduction unit do the following:



CAUTION: The o-ring can only be installed on a reduction unit adapter with the hub turned down. For complete details refer to Borg Warner Automotive Service Bulletin MB62.

Lubricate o-ring (35) with vasoline and install on center hub of reduction unit adapter (39).

NOTE: Be sure o-ring (35) is not twisted, cut, or distorted. Replace if damaged.

Install lube oil strainer (34) on reduction unit adapter (39).

STEP 11. Place pinion carrier gasket (33) on lube oil strainer (34).

STEP 12. Install pinion carrier (24) on pinion carrier gasket (33) and align bolt holes.

For 1.91:1 reduction units install three lockplates (23) and thread six bolts (21) into reduction unit adapter (39) until finger tight.

For 1.88:1 reduction units thread six bolts (21) with lockwashers (22) into reduction unit adapter (39) until finger tight.

Slide sun gear (25) partially into pinion carrier (24). Turn sun gear (25) by hand to be sure pinion carrier (24) is centered and pinion gears (31) turn freely.

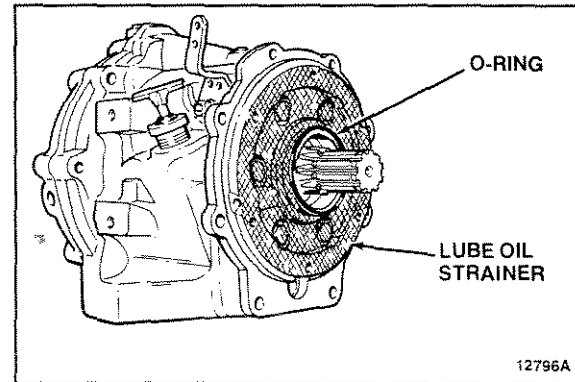

Lube Oil Strainer Installation

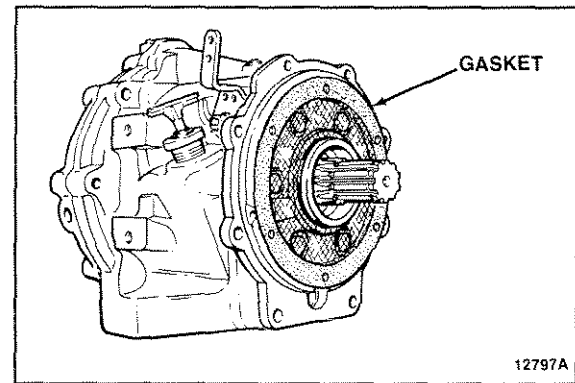

Pinion Carrier Gasket Installation.

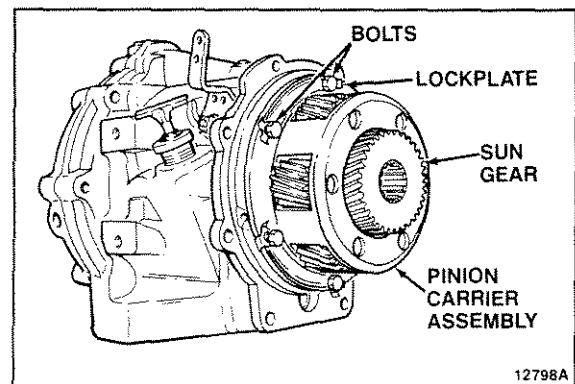

Pinion Carrier Installation

STEP 13. Tighten six bolts (21) in a criss-cross pattern to torque shown in Table 4.



CAUTION: For 1.91:1 reduction units bolts are torqued to 5 ft-lbs. Tabs on lockplates must be bent tightly against flats of bolts.

Push sun gear (20) into pinion carrier (24). Install snap ring (19) in groove of transmission output shaft.

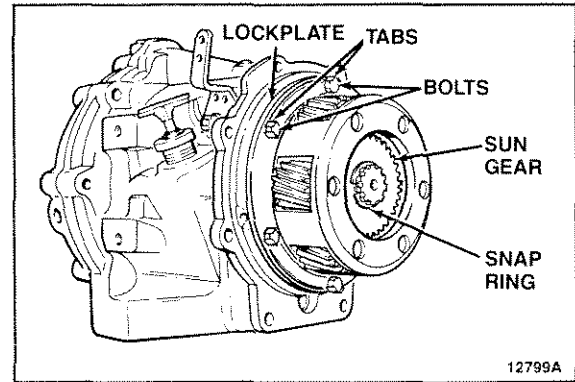

Sun Gear Installation

STEP 14. Lubricate rear adapter gasket (36) with vasoline and install on reduction unit adapter (39).

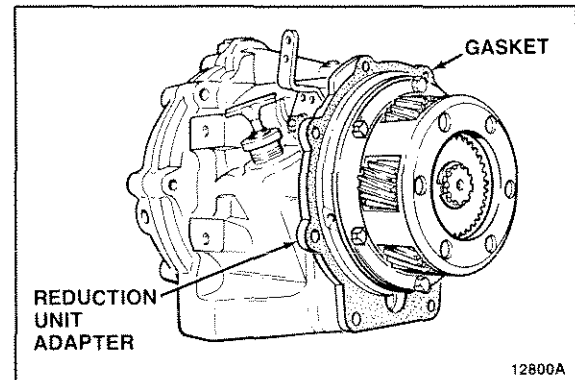

Rear Adapter Gasket Installation

STEP 15. Place reduction housing (18) on transmission. Turn coupling (6) to engage ring gear (9) with pinion gears (31).

Thread two bolts (1) with lockwashers (2) into transmission.

Thread six bolts (3) with lockwashers (4) into reduction housing (18).

Tighten bolts (1 and 3) in a criss-cross pattern to torque shown in Table 4.

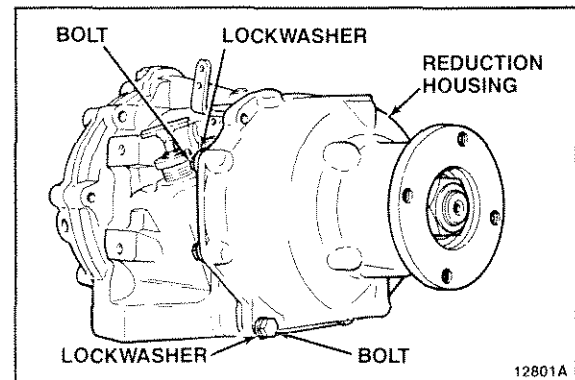

Reduction Housing Installation

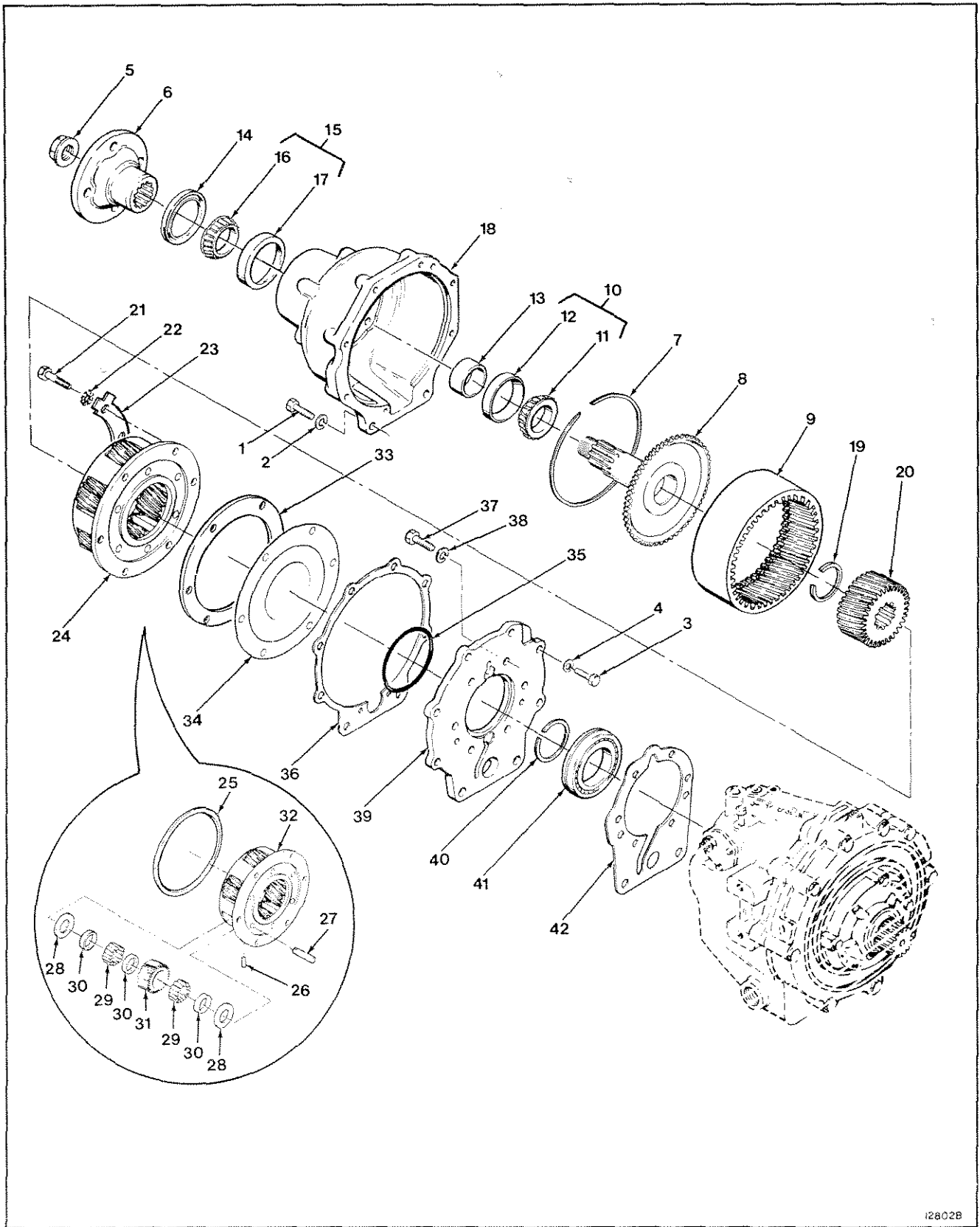

12802B

Figure 12. 1.88:1 and 1.91:1 Reduction Units - Current Production

INDEX NO.	PART NUMBER	DESCRIPTION	QTY
FIG. 12	NO NUMBER	REDUCTION UNIT ASSEMBLY (1.91:1)	
12A	NO NUMBER	REDUCTION UNIT ASSEMBLY (1.88:1)	
1	0000179864	• HEX HEAD BOLT (7/16-14 x 1-3/4)	2
2	0000103322	• LOCKWASHER (7/16)	2
3	0000179840	• HEX HEAD BOLT (3/8-18 x 1-1/8)	6
4	0000103321	• LOCKWASHER (3/8)	6
5	10-00-149-034	• COUPLING NUT	1
6	10-00-031-001	• COUPLING	1
7	4756D	• SNAP RING	1
8	10-17-171-002	• MAIN SHAFT (1.91:1 ONLY)	1
8A	10-17-171-004	• MAIN SHAFT (1.88:1 ONLY)	1
9	L3-6	• RING GEAR (1.91:1 ONLY)	1
9A	10-17-162-001	• RING GEAR (1.88:1 ONLY)	1
10	NO NUMBER	• BEARING ASSEMBLY	1
11	10-00-133-010	• • BEARING CONE *	1
12	10-00-133-009	• • BEARING CUP *	1
13	10-17-053-002	• SOLID SPACER (.820-.821 INCH LONG)**	1
13A	10-17-053-003	• SOLID SPACER (.829-.830 INCH LONG)**	1
13B	10-17-053-004	• SOLID SPACER (.832-.833 INCH LONG)**	1
13C	10-17-053-005	• SOLID SPACER (.835-.836 INCH LONG)**	1
13D	10-17-053-006	• SOLID SPACER (.838-.839 INCH LONG)**	1
13E	10-17-053-007	• SOLID SPACER (.841-.842 INCH LONG)**	1
13F	10-17-053-008	• SOLID SPACER (.844-.845 INCH LONG)**	1
13G	10-17-053-009	• SOLID SPACER (.847-.848 INCH LONG)**	1
13H	10-17-053-010	• SOLID SPACER (.850-.851 INCH LONG)**	1
13I	10-17-053-011	• SOLID SPACER (.853-.854 INCH LONG)**	1
13J	10-17-053-012	• SOLID SPACER (.856-.857 INCH LONG)**	1
14	10-00-044-017	• OIL SEAL	1
15	NO NUMBER	• BEARING ASSEMBLY	1
16	10-00-133-002	• • BEARING CONE *	1
17	10-00-133-001	• • BEARING CUP *	1
18	10-17-065-003	• REDUCTION HOUSING	1
19	4734	• SNAP RING	1
20	L7-104	• SUN GEAR (1.91:1 ONLY)	1
20A	10-17-165-004	• SUN GEAR (1.88:1 ONLY)	1
21	4853B	• LOCK BOLT (5/16-18 x 3/4)	6
22	0000114605	• LOCKWASHER (5/16) (1.88:1 ONLY)	6
23	10-00-014-002	• LOCK PLATE (1.91:1 ONLY)	3
24	L9-A150	• PINION CARRIER ASSEMBLY (1.91:1 ONLY)	1
24A	10-17-659-021	• PINION CARRIER ASSEMBLY (1.88:1 ONLY)	1
25	4827	• • RETAINING RING	1
26	4717L	• • PINION SHAFT PIN	6

* REPLACE BOTH PARTS IF ONE IS DAMAGED.

** SELECT CORRECT SIZE SPACER AT ASSEMBLY. ONLY ONE REQUIRED.

INDEX NO.	PART NUMBER	DESCRIPTION	QTY
27	L5-39	• • PINION SHAFT	6
28	L3-43	• • PINION THRUSTWASHER	12
29	4741A	• • ROLLER BEARING (1.91:1 ONLY)	288
29A	10-00-131-011	• • ROLLER BEARING (1.88:1 ONLY)	288
30	L3-41	• • PINION BEARING SPACER (1.91:1 ONLY)	6
30A	10-00-053-024	• • PINION BEARING SPACER (1.88:1 ONLY)	18
31	L4-5	• • PINION GEAR (1.91:1 ONLY)	6
31A	10-17-163-002	• • PINION GEAR (1.88:1 ONLY)	6
32	L9-150	• • PLANETARY CAGE (1.91:1 ONLY)	1
32A	10-17-159-011	• • PLANETARY CAGE (1.88:1 ONLY)	1
33	10-17-045-001	• PINION CARRIER GASKET (1.91:1 ONLY)	1
34	L9-99	• LUBE OIL STRAINER (1.91:1 ONLY)	1
35	10-00-141-149	• O-RING (1.91:1 ONLY)	1
36	L4-146	• REAR ADAPTER GASKET	1
37	10-00-183-073	• LOCK BOLT ($7/16$ -14 x $7/8$)	6
38	0000103322	• LOCKWASHER ($7/16$)	6
39	L9-8A	• REDUCTION UNIT ADAPTER ***	1
39A	10-17-172-001	• REDUCTION UNIT ADAPTER ****	1
40	4816	• SNAP RING	1
41	B308AGS	• BEARING	1
42	L4-145	• FRONT ADAPTER GASKET	1

* REPLACE BOTH PARTS IF ONE IS DAMAGED.

** SELECT CORRECT SIZE SPACER AT ASSEMBLY. ONLY ONE REQUIRED.

*** FOR USE WITH 1.91:1 NOISE REDUCTION PARTS. THESE INCLUDE LOCK PLATES (23), PINION CARRIER GASKET (33), AND O-RING (35).

**** FOR USE WITH 1.88:1 OR 1.91:1 WITHOUT NOISE REDUCTION PARTS

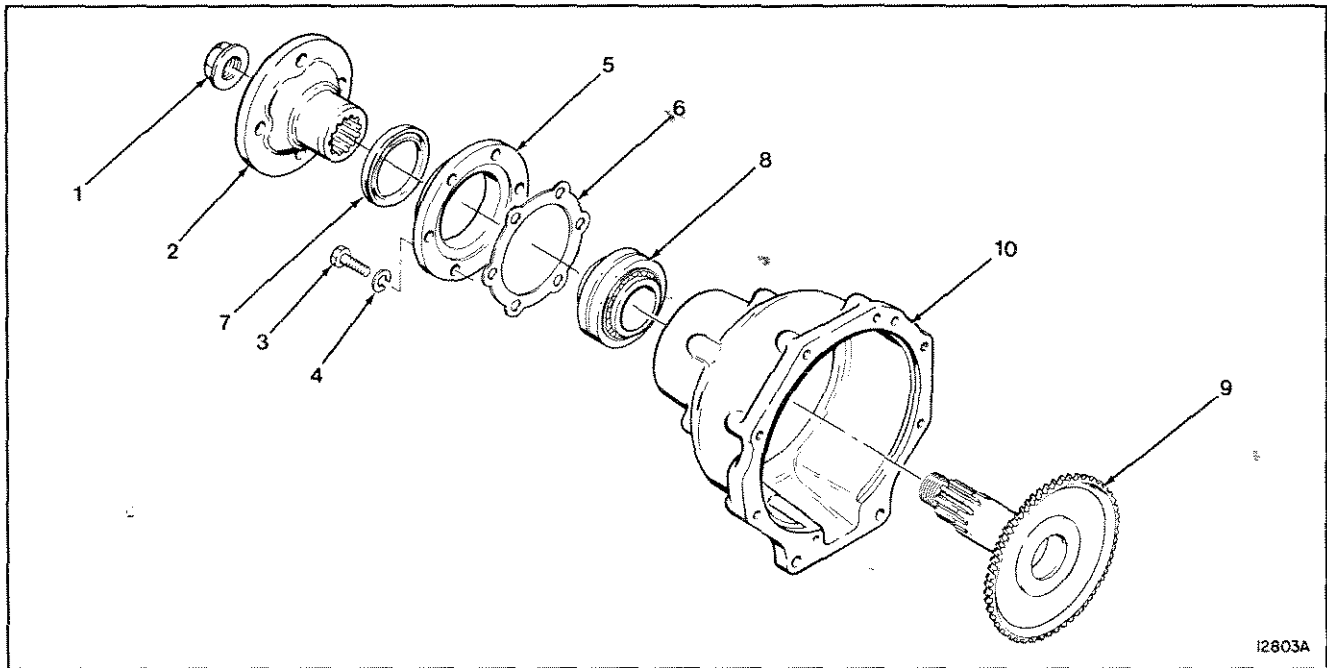

Figure 13. 1.91:1 Reduction Units - Early Production

INDEX NO.	PART NUMBER	DESCRIPTION	QTY
FIG. 13	NO NUMBER	REDUCTION UNIT (1.91:1 ONLY)	
1	4775L	• COUPLING NUT	1
2	4547AY	• COUPLING (72C ONLY)	1
2B	4547BA	• COUPLING (71C ONLY)	1
3	0000179860	• HEX HEAD BOLT (7/16-14 x 1-1/4)	6
4	0000103322	• LOCKWASHER (7/16)	6
5	L4-7	• BEARING RETAINER	1
6	L4-147	• BEARING RETAINER GASKET	1
7	71C-110	• OIL SEAL	1
8	4920A	• BEARING	1
9	L5-A2	• MAIN SHAFT	1
10	L5-1A	• REDUCTION HOUSING	1

NOTE: These early production parts are not interchangeable with current production parts in Figure 12. All other parts are the same.

2.57:1 AND 2.91:1 REDUCTION UNITS

A. DESCRIPTION

The 2.57:1 and 2.91:1 reduction units are mounted on the back of a 71C or 72C transmission. The reduction unit output shaft rotates the same direction as the input shaft on the transmission. The output shaft rotates about one turn for every two and one half to three turns of the input shaft. Lubricating oil is supplied to the reduction unit through ports on the back of the transmission.

NOTE: For inspection, maintenance, and troubleshooting refer to the Table of Contents at the front of this manual.

B. OVERHAUL

The general overhaul information described on page 12 applies to these reduction units. Before starting disassembly, review the exploded-view shown in Figure 14. The reduction unit can be disassembled following the index numbers in Figure 14. The following procedures are correct for most reduction units. Minor differences may be found.



CAUTION: Threaded plugs, screws, bolts, and coupling nut must be tightened to torque shown in Table 4 to prevent premature reduction unit failure.

- A new coupling nut must be used at assembly.
- Do not disassemble the pinion cage and output shaft assembly unless damaged. The necessary tools must be available for proper assembly. Use exploded view, Figure 14, for disassembly and assembly.
- The bearing cup and cone are a matched set. If one is damaged both must be replaced.
- A solid spacer is used to control rolling torque (end play). Rolling torque must be checked after assembly of the reduction unit, before assembly to the transmission.

NOTE: Early reduction units used a collapsible spacer. If this spacer must be replaced use the solid spacer.

NOTE: Early reduction units used a bearing retainer on the output shaft end of the reduction housing. To order correct parts refer to exploded-view, Figure 15.

STEP 1. If removed, press bearing cone (17) on pinion cage and output shaft (7).

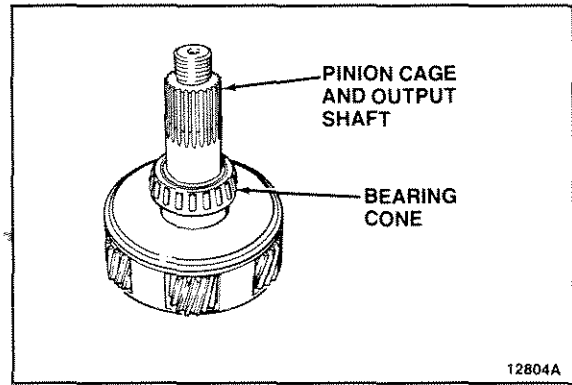

Bearing Cone Assembly

STEP 2. If removed, press bearing cups (18 and 23) into reduction housing (26).

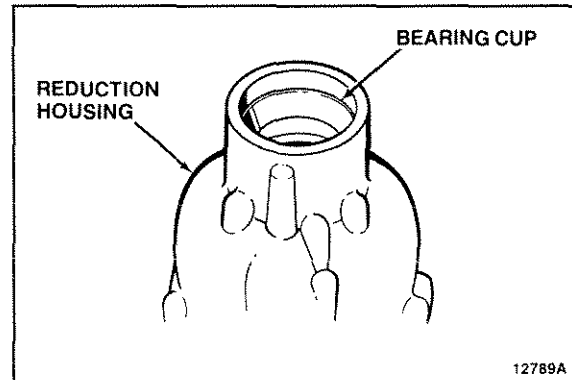

Bearing Cup Assembly

STEP 3. Place oil baffle (25) in reduction housing (26). Thread two bolts (24) into reduction housing (26). Tighten bolts (24) to torque shown in Table 4.

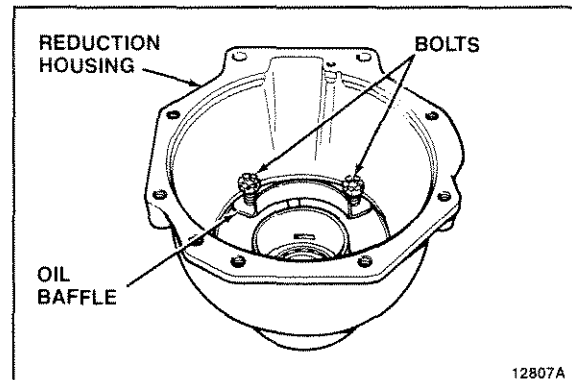

Oil Baffle Installation

STEP 4. Install pinion cage and output shaft (7) in reduction housing (26).

Support pinion cage and output shaft (7). Install original spacer (19) and bearing cone (22) in reduction housing (26).



CAUTION: If original spacer is not used the replacement spacer should be the same length. Using an incorrect size spacer can result in premature failure of reduction unit.

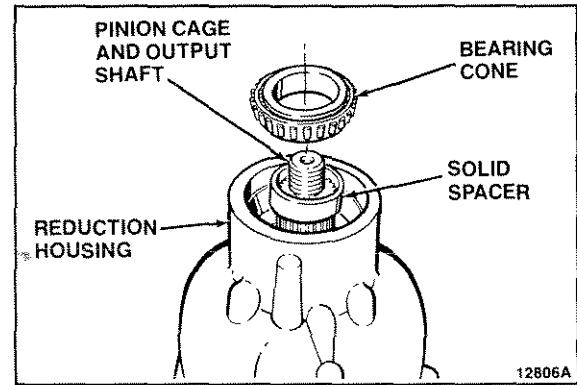

Spacer and Bearing Cone Assembly

STEP 5. Place reduction housing (26) in press with pinion cage and output shaft (7) supported. Press bearing cone (22) on pinion cage and output shaft (7). Remove reduction housing (26) from press.

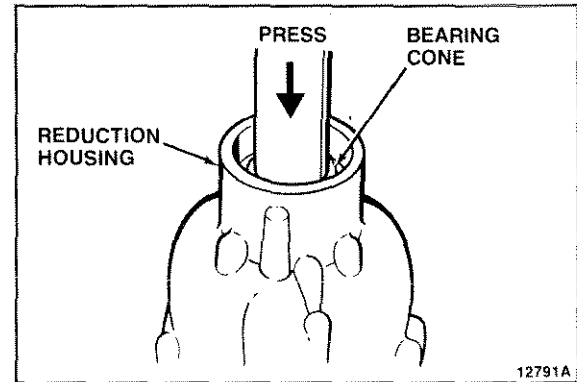

Bearing Cone Assembly

STEP 6. Install oil seal (20) in reduction housing (26). Outer surface of oil seal (20) should be flush with face of reduction housing (26).

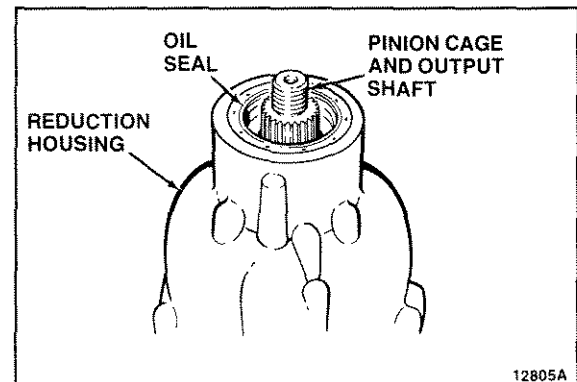

Oil Seal Assembly

STEP 7. Slide coupling (6) on pinion cage and output shaft (7). Thread nut (5) on pinion cage and output shaft (7). Tighten nut (5) to torque shown in Table 4.

Attach a torque wrench to nut (5). Turn torque wrench to check rolling torque of bearings (17 and 22). Rolling torque should be 5 to 30 in-lbs.

If rolling torque is over 30 in-lbs replace spacer (13) with a longer one. If rolling torque is under 5 in-lbs replace spacer (13) with a shorter one.

NOTE: Selection of the proper spacer (19) will result in 0 to 0.005 inch end play.

STEP 8. If removed, install bearing (37) and snap ring (36) in transmission.

Lubricate front adapter gasket (38) with vasoline and install on transmission.

STEP 9. Install stationary gear plate (32) in ring gear (33). Install snap ring (31) in groove of ring gear (33).

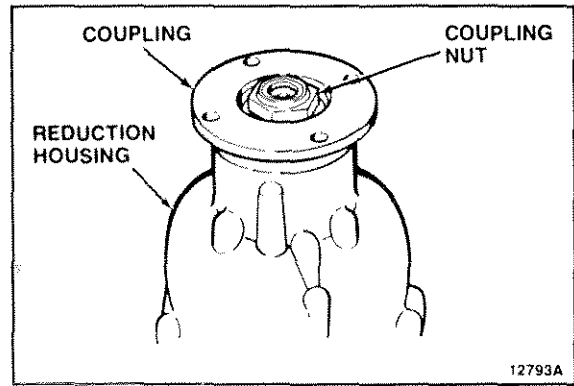

Coupling Assembly

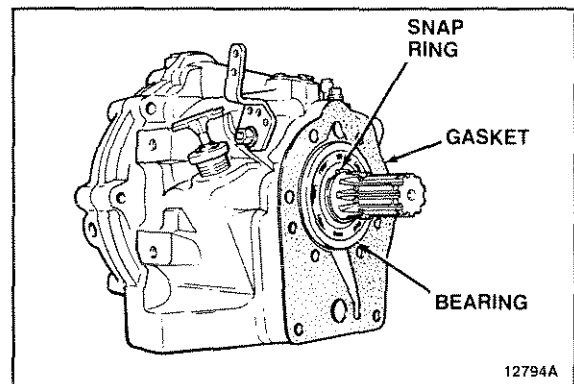

Front Adapter Gasket Installation

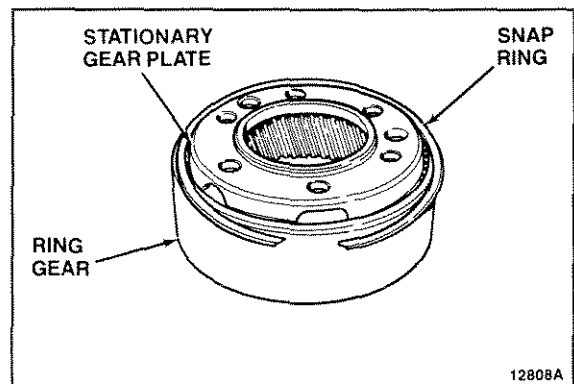

Stationary Gear Plate Assembly

STEP 10. Install reduction unit adapter (35) and ring gear (33) on transmission.

Thread six bolts (29) with lockwashers (30) into transmission. Tighten bolts (29) in a criss-cross pattern to torque shown in Table 4.

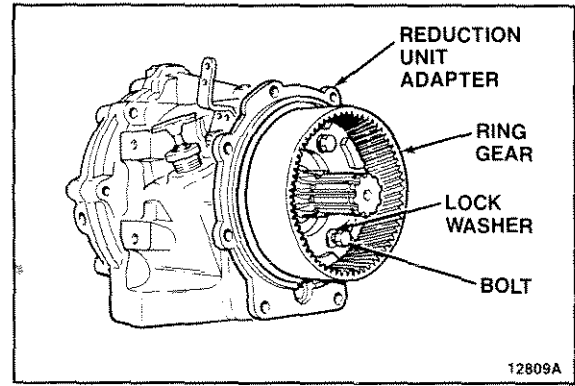

Reduction Unit Adapter Installation

STEP 11. Slide sun gear (28) on transmission output shaft.

Install snap ring (27) in groove of output shaft.

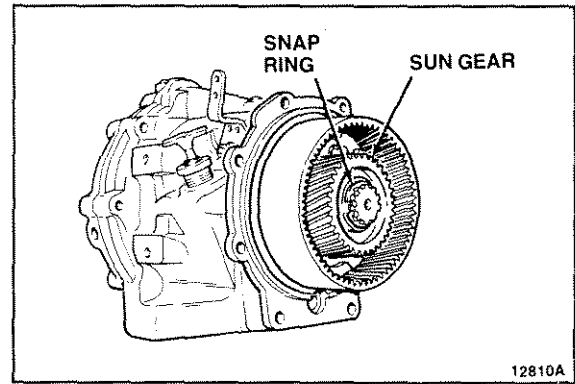

Sun Gear Installation

STEP 12. Lubricate rear adapter gasket (34) with vasoline and install on reduction unit adapter (35).

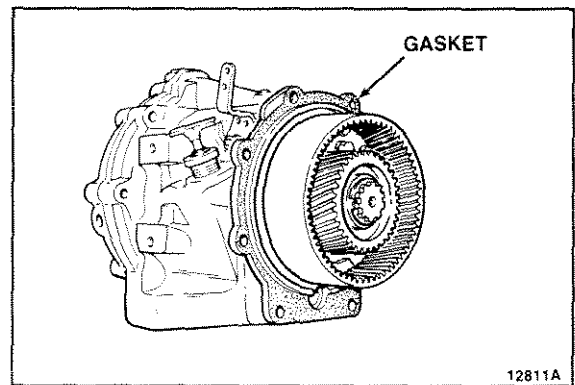

Rear Adapter Gasket Installation

STEP 13. Place reduction housing (26) on transmission. Turn coupling (6) to engage pinion gears (14) with ring gear (33).

Thread two bolts (1) with lockwashers (2) into transmission.

Thread six bolts (3) with lockwashers (4) into reduction housing (18).

Tighten bolts (1 and 3) in a criss-cross pattern to torque shown in Table 4.

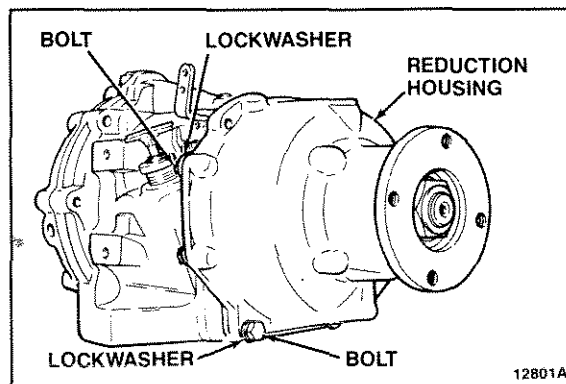

Reduction Housing Installation.

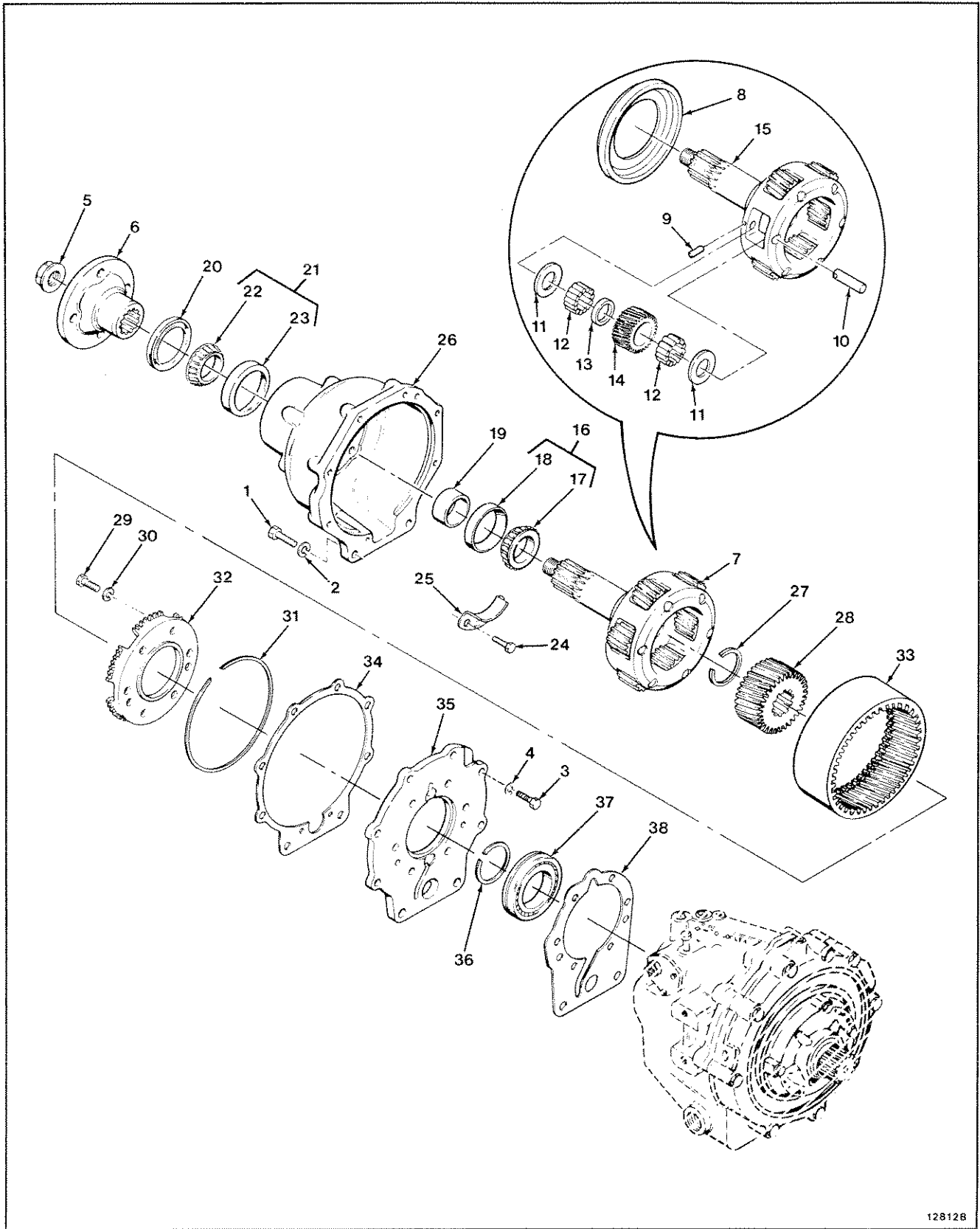

128128

Figure 14. 2.57:1 and 2.91:1 Reduction Units - Current Production

INDEX NO.	PART NUMBER	DESCRIPTION	QTY
FIG. 14	NO NUMBER	REDUCTION UNIT ASSEMBLY (2.57:1)	
14A	NO NUMBER	REDUCTION UNIT ASSEMBLY(2.91:1)	
1	0000179864	• HEX HEAD BOLT (7/16-14 x 1-3/4)	2
2	0000103322	• LOCKWASHER (7/16)	2
3	0000179840	• HEX HEAD BOLT (3/8-18 x 1-1/8)	6
4	0000103321	• LOCKWASHER (3/8)	6
5	10-00-149-034	• COUPLING NUT	1
6	10-00-031-001	• COUPLING	1
7	10-17-659-007	• PINION CAGE AND OUTPUT SHAFT ASSEMBLY (2.57:1 ONLY)	1
7A	10-17-659-008	• PINION CAGE AND OUTPUT SHAFT ASSEMBLY (2.91:1 ONLY)	1
8	L6-135	• • OIL COLLECTOR RING (2.57:1 ONLY)	1
8A	L4-135	• • OIL COLLECTOR RING (2.91:1 ONLY)	1
9	R10B-40	• • PINION SHAFT PIN (2.57:1 ONLY)	6
9A	4717B	• • PINION SHAFT PIN (2.91:1 ONLY)	6
10	L5-39	• • PINION SHAFT	6
11	L6-43	• • THRUSTWASHER (2.57:1 ONLY)	12
11A	L3-43	• • THRUSTWASHER (2.91:1 ONLY)	12
12	4741A	• • ROLLER BEARING	288
13	L3-41	• • PINION BEARING SPACER	6
14	L6-5	• • PINION GEAR (2.57:1 ONLY)	6
14A	L4-5	• • PINION GEAR (2.91:1 ONLY)	6
15	10-17-159-003	• • PINION CAGE AND OUTPUT SHAFT (2.57:1 ONLY)	1
15A	10-17-159-004	• • PINION CAGE AND OUTPUT SHAFT (2.91:1 ONLY)	1
16	NO NUMBER	• BEARING ASSEMBLY	1
17	10-00-133-010	• • BEARING CONE *	1
18	10-00-133-009	• • BEARING CUP *	1
19	10-17-053-002	• SOLID SPACER (.820-.821 INCH LONG) **	1
19A	10-17-053-003	• SOLID SPACER (.829-.830 INCH LONG) **	1
19B	10-17-053-004	• SOLID SPACER (.832-.833 INCH LONG) **	1
19C	10-17-053-005	• SOLID SPACER (.835-.836 INCH LONG) **	1
19D	10-17-053-006	• SOLID SPACER (.838-.839 INCH LONG) **	1
19E	10-17-053-007	• SOLID SPACER (.841-.842 INCH LONG) **	1
19F	10-17-053-008	• SOLID SPACER (.844-.845 INCH LONG) **	1
19G	10-17-053-009	• SOLID SPACER (.847-.848 INCH LONG) **	1
19H	10-17-053-010	• SOLID SPACER (.850-.851 INCH LONG) **	1
19I	10-17-053-011	• SOLID SPACER (.853-.854 INCH LONG) **	1
19J	10-17-053-012	• SOLID SPACER (.856-.857 INCH LONG) **	1
20	10-00-044-017	• OIL SEAL	1
21	NO NUMBER	• BEARING ASSEMBLY	1

* REPLACE BOTH PARTS IF ONE IS DAMAGED.

** SELECT CORRECT SIZE SPACER AT ASSEMBLY. ONLY ONE REQUIRED.

INDEX NO.	PART NUMBER	DESCRIPTION	QTY
22	10-00-133-002	• • BEARING CONE *	1
23	10-00-133-001	• • BEARING CUP *	1
24	4776BB	• LOCK BOLT (7/16-14 x 7/8)	2
25	10-17-036-001	• OIL BAFFLE	1
26	10-17-065-001	• REDUCTION HOUSING	1
27	4734	• SNAP RING	1
28	L6-104	• SUN GEAR (2.57:1 ONLY)	1
28A	L7-104	• SUN GEAR (2.91:1 ONLY)	1
29	4853E	• LOCK BOLT (7/16-14 x 1-1/4)	6
30	0000115550	• LOCKWASHER (7/16)	6
31	4756E	• SNAP RING (2.57:1 ONLY)	1
31A	4756D	• SNAP RING (2.91:1 ONLY)	1
32	L6-31	• STATIONARY GEAR PLATE (2.57:1 ONLY)	1
32A	L7-31	• STATIONARY GEAR PLATE (2.91:1 ONLY)	1
33	L6-6	• RING GEAR (2.57:1 ONLY)	1
33A	L3-6	• RING GEAR (2.91:1 ONLY)	1
34	L4-146	• REAR ADAPTER GASKET	1
35	L7-8A	• REDUCTION UNIT ADAPTER	1
36	4816	• SNAP RING	1
37	B308AGS	• BEARING	1
38	L4-145	• FRONT ADAPTER GASKET	1

* REPLACE BOTH PARTS IF ONE IS DAMAGED.

** SELECT CORRECT SIZE SPACER AT ASSEMBLY. ONLY ONE REQUIRED.

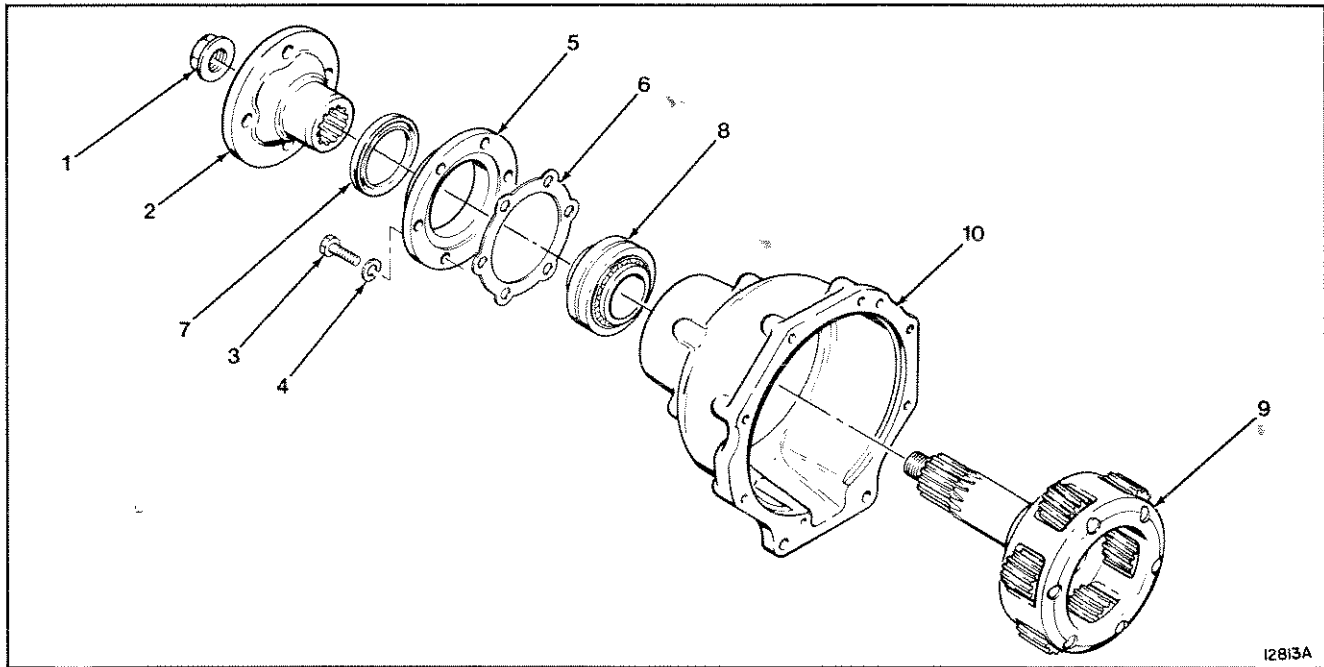

Figure 15. 2.57:1 AND 2.91:1 Reduction Units - Early Production

INDEX NO.	PART NUMBER	DESCRIPTION	QTY
FIG. 15	NO NUMBER	REDUCTION UNIT (2.57:1 ONLY)	
15A	NO NUMBER	REDUCTION UNIT (2.91:1 ONLY)	
1	10-00-149-034	• COUPLING NUT	1
2	4912	• COUPLING	1
3	0000179860	• HEX HEAD BOLT (7/16-14 x 1-1/4)	6
4	0000103322	• LOCKWASHER (7/16)	6
5	L4-7	• BEARING RETAINER	1
6	L4-147	• BEARING RETAINER GASKET	1
7	71C-110	• OIL SEAL	1
8	4920	• BEARING	1
9	L6-A2D	• PINION CAGE AND OUTPUT SHAFT ASSEMBLY (2.57:1 ONLY)	1
9A	L7-A2D	• PINION CAGE AND OUTPUT SHAFT ASSEMBLY (2.91:1 ONLY)	1
10	L7-1A	• REDUCTION HOUSING	1

NOTE: These early production parts are not interchangeable with current production parts in Figure 14. All other parts are the same.

2.10:1 REDUCTION UNIT

A. DESCRIPTION

The 2.10:1 reduction unit is mounted on the back of a 71C or 72C transmission. The reduction unit output shaft rotates the same direction as the input shaft on the transmission. The output shaft rotates about one turn for every two turns of the input shaft. Lubricating oil is supplied to the reduction unit through ports on the back of the transmission.

NOTE: For inspection, maintenance, and troubleshooting refer to the Table of Contents at the front of this manual.

B. OVERHAUL

The general overhaul information described on page 12 applies to these reduction units. Before starting disassembly, review the exploded-view shown in Figure 16. The reduction unit can be disassembled following the index numbers in Figure 16. The following procedures are correct for most reduction units. Minor differences may be found.



CAUTION: Threaded plugs, screws, bolts, and coupling nut must be tightened to torque shown in Table 4 to prevent premature reduction unit failure.

- A new coupling nut must be used at assembly.
- Do not disassemble the pinion carrier assembly unless damaged. The necessary tools must be available for proper assembly. Use the exploded view, Figure 16, for disassembly and assembly.
- The bearing cup and cone are a matched set. If one is damaged both must be replaced.
- A solid spacer is used to control rolling torque (end play). Rolling torque must be checked after assembly of the reduction unit, before assembly to the transmission.

NOTE: Early reduction units used a collapsible spacer. If this spacer must be replaced use the solid spacer.

NOTE: Early reduction units used a bearing retainer on the output shaft end of reduction housing. To order correct parts refer to exploded-view, Figure 17.

STEP 1. If removed, press bearing cone (12) on output shaft (8).

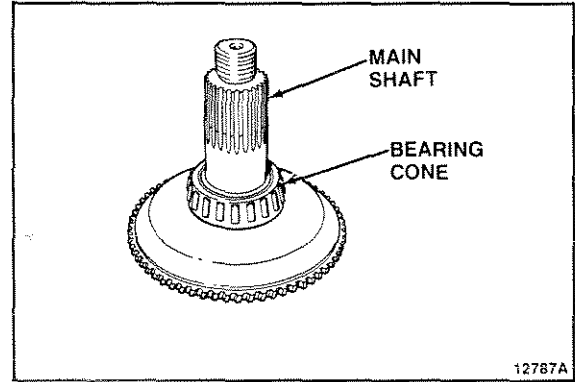

Bearing Cone Assembly

STEP 2. If removed, install bushing (9) in output shaft (8).

Install output shaft (8) in ring gear (9). Install snap ring (7) in groove of ring gear (10).

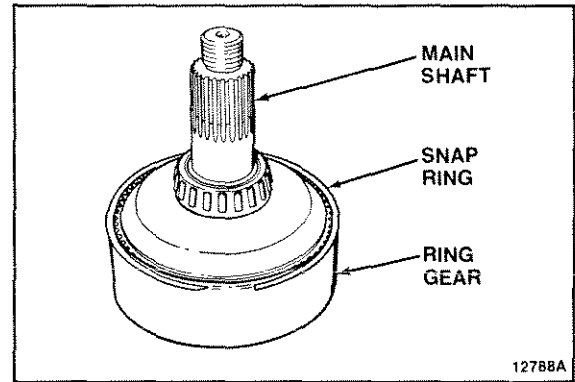

Output Shaft Assembly

STEP 3. If removed, press bearing cups (13 and 18) into reduction housing (20).

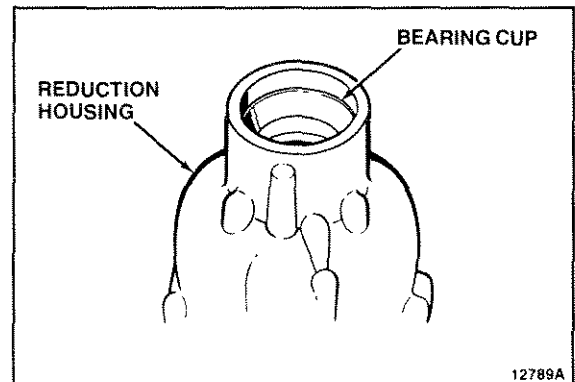

Bearing Cup Assembly

STEP 4. Install output shaft (8) and ring gear (10) in reduction housing (20).

Turn reduction housing (20) over and install original spacer (14) and bearing cone (17) in reduction housing (20).



CAUTION: If original spacer is not used the replacement spacer should be the same length. Using an incorrect size spacer can result in premature failure of reduction unit.

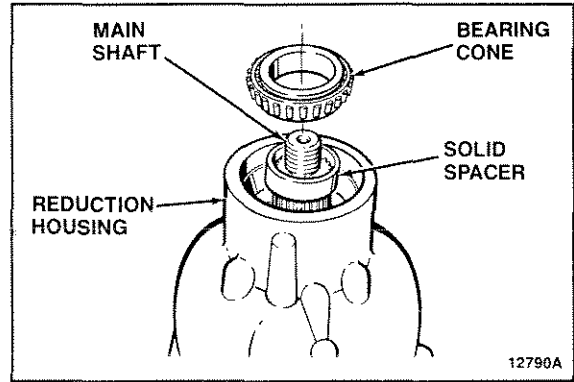

Spacer and Bearing Cone Assembly

STEP 5. Place reduction housing (20) in press with ring gear (10) supported. Press bearing cone (17) on output shaft (8). Remove reduction housing (20) from press.

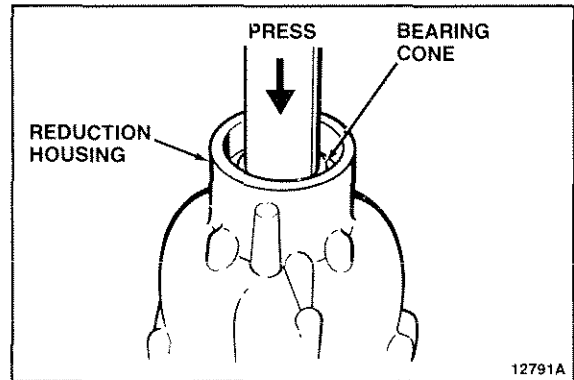

Bearing Cone Assembly

STEP 6. Install oil seal (15) in reduction housing (20). Outer surface of oil seal (15) should be flush with reduction housing (20) face.

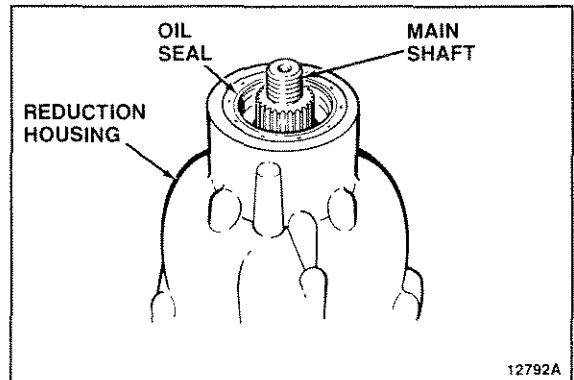

Oil Seal Assembly

STEP 7. Slide coupling (6) on output shaft (8). Thread nut (5) on output shaft (8). Tighten nut (5) to torque shown in Table 4.

Attach a torque wrench to nut (5). Turn torque wrench to check rolling torque of bearings (12 and 17). Rolling torque should be 5 to 30 in-lbs.

If rolling torque is over 30 in-lbs replace spacer (14) with a longer one. If rolling torque is under 5 in-lbs replace spacer (14) with a shorter one.

NOTE: Selection of the proper spacer (14) will result in 0 to 0.005 inch end play.

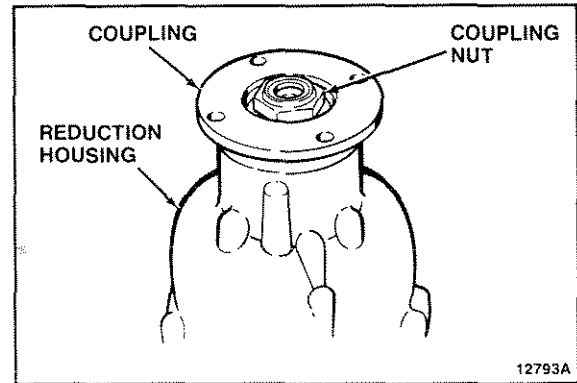

Coupling Assembly

STEP 8. Lubricate front adapter gasket (43) with vasoline and install on transmission.

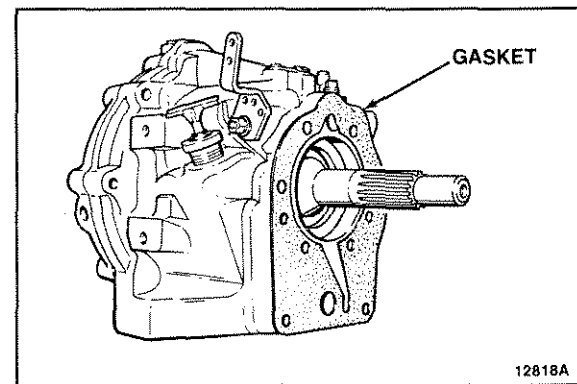

Front Adapter Gasket Installation

STEP 9. Slide sun gear (41) into reduction unit adapter (42).

Turn reduction unit adapter (42) over. Install snap ring (40) in groove of sun gear (41).

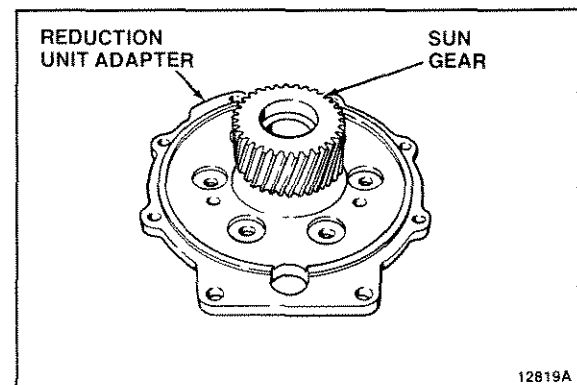

Sun Gear Assembly

STEP 10. Install reduction unit adapter (42) on transmission.

Thread six bolts (38) with lockwashers (39) into transmission. Tighten bolts (38) in a criss-cross pattern to torque shown in Table 4.

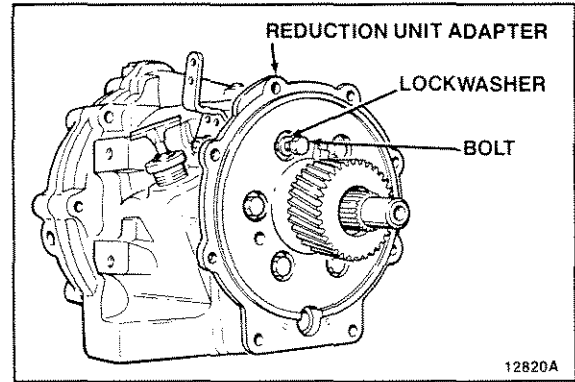

Reduction Unit Adapter Installation

STEP 11. Lubricate one thrustwasher (21) with vasoline and install on sun gear (41).

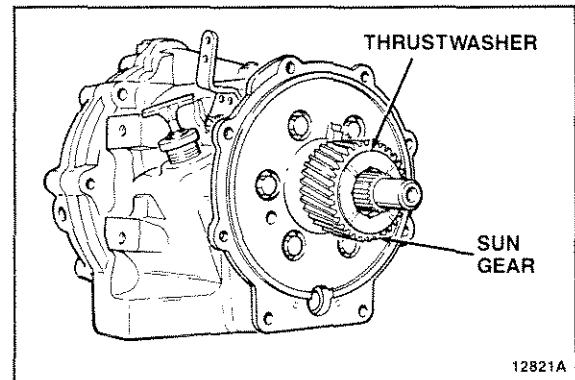

Thrustwasher Installation

STEP 12. Slide pinion cage assembly (22) on transmission output shaft.

Lubricate thrustwasher (21) with vasoline and install on pinion cage assembly (22).

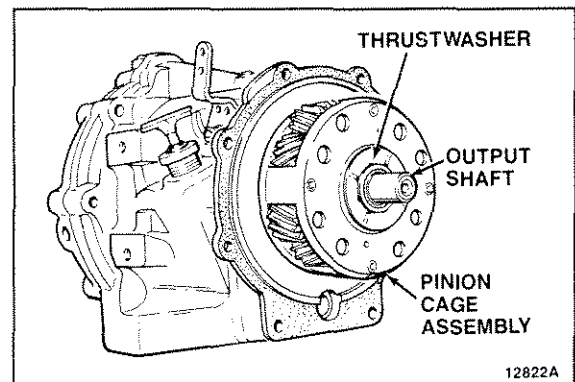

Pinion Cage Installation

STEP 13. Lubricate rear adapter gasket (37) with vasoline and install on reduction unit adapter (42).

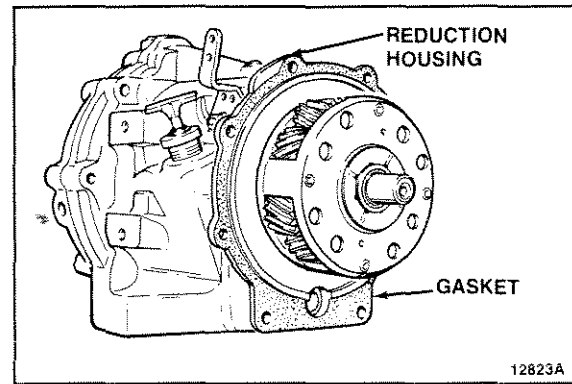

Rear Adapter Gasket Installation

STEP 14. Place reduction housing (20) on transmission. Turn coupling (6) to engage ring gear (10) with pinion gears (29 and 35).

Thread two bolts (1) with lockwashers (2) into transmission.

Thread six bolts (3) with lockwashers (4) into reduction housing (20).

Tighten bolts (1 and 3) in a criss-cross pattern to torque shown in Table 4.

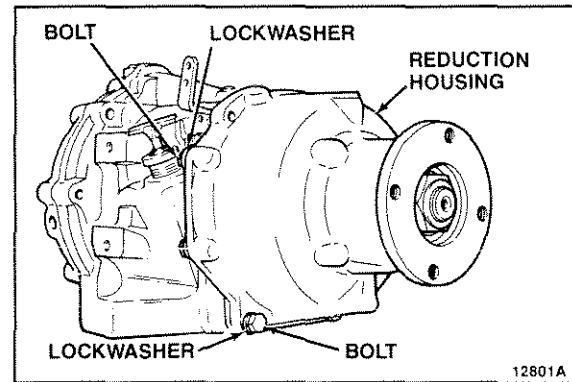

Reduction Housing Installation

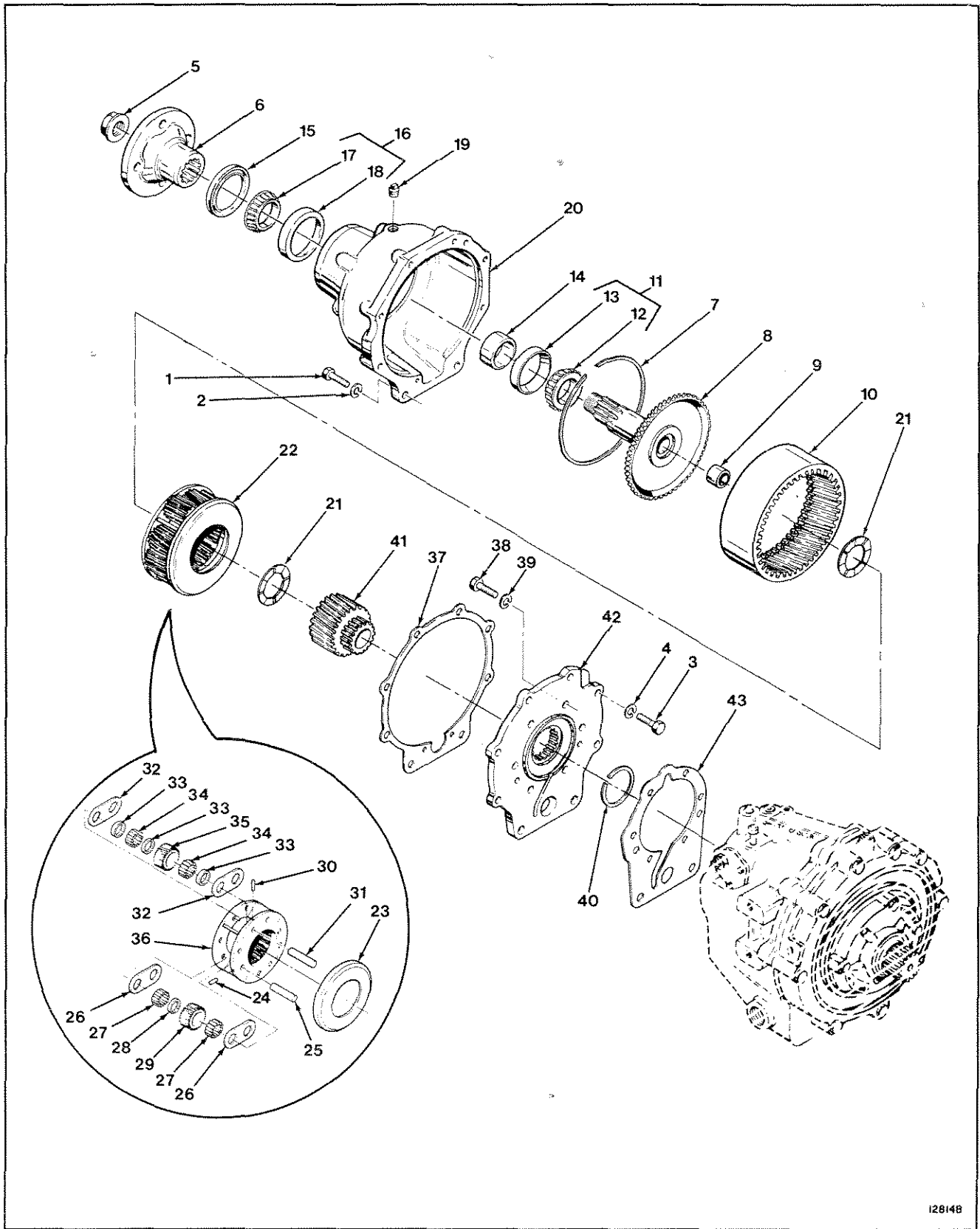

128148

Figure 16. 2.10:1 Reduction Units - Current Production

INDEX NO.	PART NUMBER	DESCRIPTION	QTY
FIG. 16	NO NUMBER	REDUCTION UNIT ASSEMBLY(2.10:1)	
1	0000179864	• HEX HEAD BOLT (7/16-14 x 1-3/4)	2
2	0000103322	• LOCKWASHER (7/16)	2
3	0000179840	• HEX HEAD BOLT (3/8-18 x 1-1/8)	6
4	0000103321	• LOCKWASHER (3/8)	6
5	10-00-149-034	• COUPLING NUT	1
6	10-00-031-001	• COUPLING	1
7	4756D	• SNAP RING	1
8	10-17-671-001	• OUTPUT SHAFT AND BUSHING ASSEMBLY	1
9	A4867DD	• • BUSHING (KIT)	1
10	L3-6	• RING GEAR	1
11	NO NUMBER	• BEARING ASSEMBLY	1
12	10-00-133-010	• • BEARING CONE *	1
13	10-00-133-009	• • BEARING CUP *	1
14	10-17-053-002	• SOLID SPACER (.820-.821 INCH LONG) **	1
14A	10-17-053-003	• SOLID SPACER (.829-.830 INCH LONG) **	1
14B	10-17-053-004	• SOLID SPACER (.832-.833 INCH LONG) **	1
14C	10-17-053-005	• SOLID SPACER (.835-.836 INCH LONG) **	1
14D	10-17-053-006	• SOLID SPACER (.838-.839 INCH LONG) **	1
14E	10-17-053-007	• SOLID SPACER (.841-.842 INCH LONG) **	1
14F	10-17-053-008	• SOLID SPACER (.844-.845 INCH LONG) **	1
14G	10-17-053-009	• SOLID SPACER (.847-.848 INCH LONG) **	1
14H	10-17-053-010	• SOLID SPACER (.850-.851 INCH LONG) **	1
14I	10-17-053-011	• SOLID SPACER (.853-.854 INCH LONG) **	1
14J	10-17-053-012	• SOLID SPACER (.856-.857 INCH LONG) **	1
15	10-00-044-017	• OIL SEAL	1
16	NO NUMBER	• BEARING ASSEMBLY	1
17	10-00-133-002	• • BEARING CONE *	1
18	10-00-133-001	• • BEARING CUP *	1
19	10-00-191-002	• PLASTIC PLUG	1
20	10-17-065-002	• REDUCTION HOUSING	1
21	L3-24	• THRUSTWASHER	2
22	10-17-659-006	• PINION CAGE ASSEMBLY ***	1
22A	10-17-659-010	• PINION CAGE ASSEMBLY ****	1
23	L4-135	• • OIL COLLECTOR RING	1
24	4717L	• • PINION SHAFT PIN	4
25	L5-39A	• • PINION SHAFT	4
26	72-43	• • PINION THRUST PLATE	4
27	4741A	• • ROLLER BEARING	192
28	L3-41	• • PINION BEARING SPACER	4

* REPLACE BOTH PARTS IF ONE IS DAMAGED.

** SELECT CORRECT SIZE SPACER AT ASSEMBLY. ONLY ONE REQUIRED.

*** USED WITH TRANSMISSIONS 10-17-000-009 AND 10-18-000-007. HAS DRILL SPOTS ON PLANETARY CAGE FOR IDENTIFICATION.

**** USED WITH TRANSMISSIONS 10-17-000-010 AND 10-18-000-008.

INDEX NO.	PART NUMBER	DESCRIPTION	QTY
29	L3-105	• • RH PINION GEAR	4
30	R4-40	• • PINION SHAFT PIN	4
31	L5-39	• • PINION SHAFT	4
32	72-43	• • PINION THRUST PLATE	4
33	L3-41	• • PINION BEARING SPACER	12
34	4741A	• • ROLLER BEARING	192
35	L3-5	• • LH PINION GEAR	4
36	10-17-659-005	• • PLANETARY CAGE ASSEMBLY ***	1
36A	10-17-659-009	• • PLANETARY CAGE ASSEMBLY ****	1
37	L4-146	• REAR ADAPTER GASKET	1
38	10-00-183-073	• LOCK BOLT (7/16-14 x 7/8)	6
39	115550	• LOCKWASHER (7/16)	6
40	4766A	• SNAP RING	1
41	10-17-165-002	• SUN GEAR	1
42	L5-8A	• REDUCTION UNIT ADAPTER	1
43	L4-145	• FRONT ADAPTER GASKET	1

* REPLACE BOTH PARTS IF ONE IS DAMAGED.

** SELECT CORRECT SIZE SPACER AT ASSEMBLY. ONLY ONE REQUIRED.

*** USED WITH TRANSMISSIONS 10-17-000-009 AND 10-18-000-007. HAS DRILL SPOTS ON PLANETARY CAGE FOR IDENTIFICATION.

**** USED WITH TRANSMISSIONS 10-17-000-010 AND 10-18-000-008.

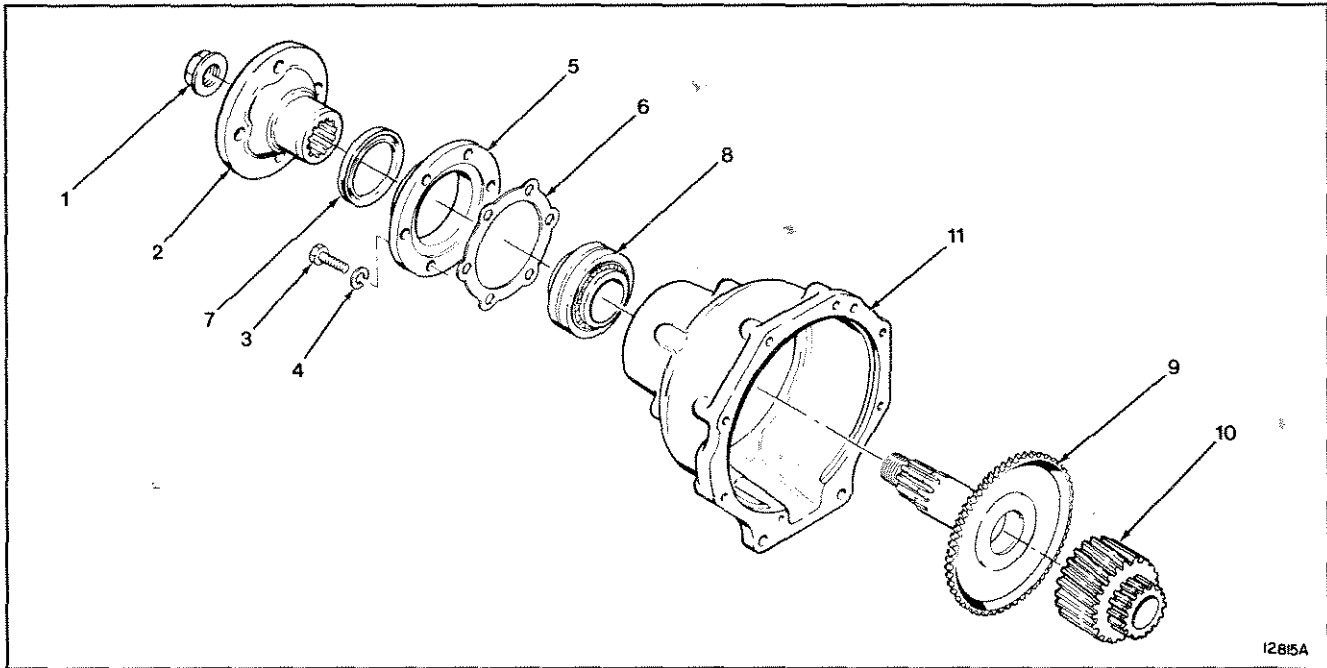

Figure 17. 2.10:1 Reduction Units - Early Production

INDEX NO.	PART NUMBER	DESCRIPTION	QTY
FIG. 17	NO NUMBER	REDUCTION UNIT (2.10:1)	
1	4775L	• COUPLING NUT	1
2	4547AY	• COUPLING (72C ONLY)	1
2B	4547BA	• COUPLING (71C ONLY)	1
3	0000179860	• HEX HEAD BOLT (7/16-14 x 1-1/4)	6
4	0000103322	• LOCKWASHER (7/16)	6
5	L4-7	• BEARING RETAINER	1
6	L4-147	• BEARING RETAINER GASKET	1
7	71C-110	• OIL SEAL	1
8	4920A	• BEARING	1
9	L5-A2	• OUTPUT SHAFT AND BUSHING ASSEMBLY	1
10	L5-4	• SUN GEAR	1
11	L5-1B	• REDUCTION HOUSING	1

NOTE: These early production parts are not interchangeable with current production parts in Figure 16. All other parts are the same.

BLANK



BorgWarner Marine & Industrial Transmissions

Distributed By:

**Borg-Warner
Automotive
Diversified
Transmission
Products Corporation**

**Marine &
Industrial
Transmissions**

**5401
Kilgore
Avenue**

**Muncie
Indiana
47304**

**Telephone
317/286-6100
Telex:
27-491
Fax:
317/286-6891**

**Borg-Warner
Automotive
GmbH**

**Marine &
Industrial
Transmissions**

**Kenfig
Industrial Estate
Margam Nr.
Port Talbot**

**West Glamorgan
SA13 2PG
United Kingdom**

**Telephone
656-741001
Telex:
85149861
Fax:
656-747811**